



Bio[®]
GS

ULTRA QUIET AIR PURIFIER

HELLO!

OWNER'S MANUAL
MODELS: SPA-550A
SPA-625A

24/7 CUSTOMER CARE



For Questions: Call 888.866.8862
Visit us at www.rabbitair.com

HELLO THERE!

“

Meet your brand new BioGS!
We hope that this stylish bundle of cleanliness is just what you've been looking for. Be sure to get familiar with this newest addition to your home, by exploring all of its features in the enclosed booklet and on our website. If you have any questions just give us a call, anytime. We love to hear from you!

”

GENERAL SAFETY INFORMATION ABOUT YOUR BIOGS AIR PURIFIER

Caution: When using electrical appliances, observe the following basic precautions to reduce the risk of fire, electric shock, and injury:

- Please read all tips and warnings before using your Rabbit Air purifier.
- Use only as directed by the Owner's Manual.
- Please observe extreme caution when using the air purifier in close proximity to children.
- Rabbit Air purifiers are for indoor use only.
- The Rabbit Air purifier is not intended for use in bathrooms, laundry areas, or other damp indoor environments. Keep the Rabbit Air purifier away from water at all times.
- Do not use the Rabbit Air purifier near fireplaces or in areas where flammable or combustible products or vapors may be present.
- This appliance has a polarized plug (one blade is wider than the other) . To reduce the risk of electric shock, this plug is intended to fit in a polarized outlet only one way. If the plug does not fit fully in the outlet, reverse the plug. If it still does not fit, contact a qualified electrician. Do not attempt to defeat this safety feature.

ELECTRICAL SAFETY INSTRUCTIONS

- The Rabbit Air purifier is designed for use in a 110/120V outlet only.
- Turn off your Rabbit Air purifier before unplugging it from the power outlet.
- Unplug the Rabbit Air purifier from the power outlet when not in use and before servicing or cleaning the unit.
- To reduce the risk of electric shock, the Rabbit Air purifier has a polarized plug, which means it will fit into a polarized outlet only one way. If the plug does not fit into the outlet, reverse the plug. If it still does not fit, contact qualified personnel to install the proper outlet. Do not alter the plug in any way.
- To avoid electric shock, do not touch the air purifier or its power plug with wet hands.
- Keep the electrical cord away from heated surfaces at all times.
- If the cord or plug appears damaged, return the unit immediately to an authorized service facility for examination and repair.
- Any attempts to repair the Rabbit Air purifier without written permission from Rabbit Air will void the warranty and could cause serious personal injury to the user and/or result in severe damage to the unit.
- Do not pull, carry, lift, or drag the Rabbit Air purifier by pulling its power cord. Remove the power plug from its outlet by grasping the plug and pulling gently.
- When the Rabbit Air purifier is plugged into a power outlet, keep all fingers, body parts, hair, jewelry, and loose clothing away from the openings.

INSTALLATION GUIDELINES

- Avoid putting the Rabbit Air purifier in a place where the air intake or air outlet could become clogged with dirt.
- Leave at least two feet of space between the air purifier's intake, outlet, and the wall.

OPERATION GUIDELINES

- Do not block the air intake or air outlet.
- Do not use the Rabbit Air purifier on or around hot surfaces.
- Do not use the Rabbit Air purifier in a room where it may come into contact with steam.
- Do not operate the Rabbit Air purifier on its side.
- Do not install the Rabbit Air purifier in greasy or damp environments.
- Do not use detergent or soap to clean the Rabbit Air purifier.
- Do not operate the Rabbit Air purifier without filters.
- Do not wash and reuse the filters except for the washable Pre-Filter.
- When transporting the Rabbit Air purifier, always hold the handle on the back of the unit.

REMOTE CONTROL TIPS

- Inverter lighting equipment or electronic light fixtures may interfere with remote control signals.
- Avoid storing the remote control in direct sunlight. Heat may interfere with remote control signals.

The Energy Star label and disclaimer:

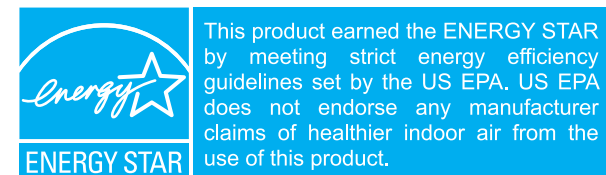

The energy efficiency of this ENERGY STAR qualified model is measured based on a ratio between the model's CADR for dust and the electrical energy it consumes, or CADR/Watt.

MEET YOUR BIOGS 2.0

TOP VIEW

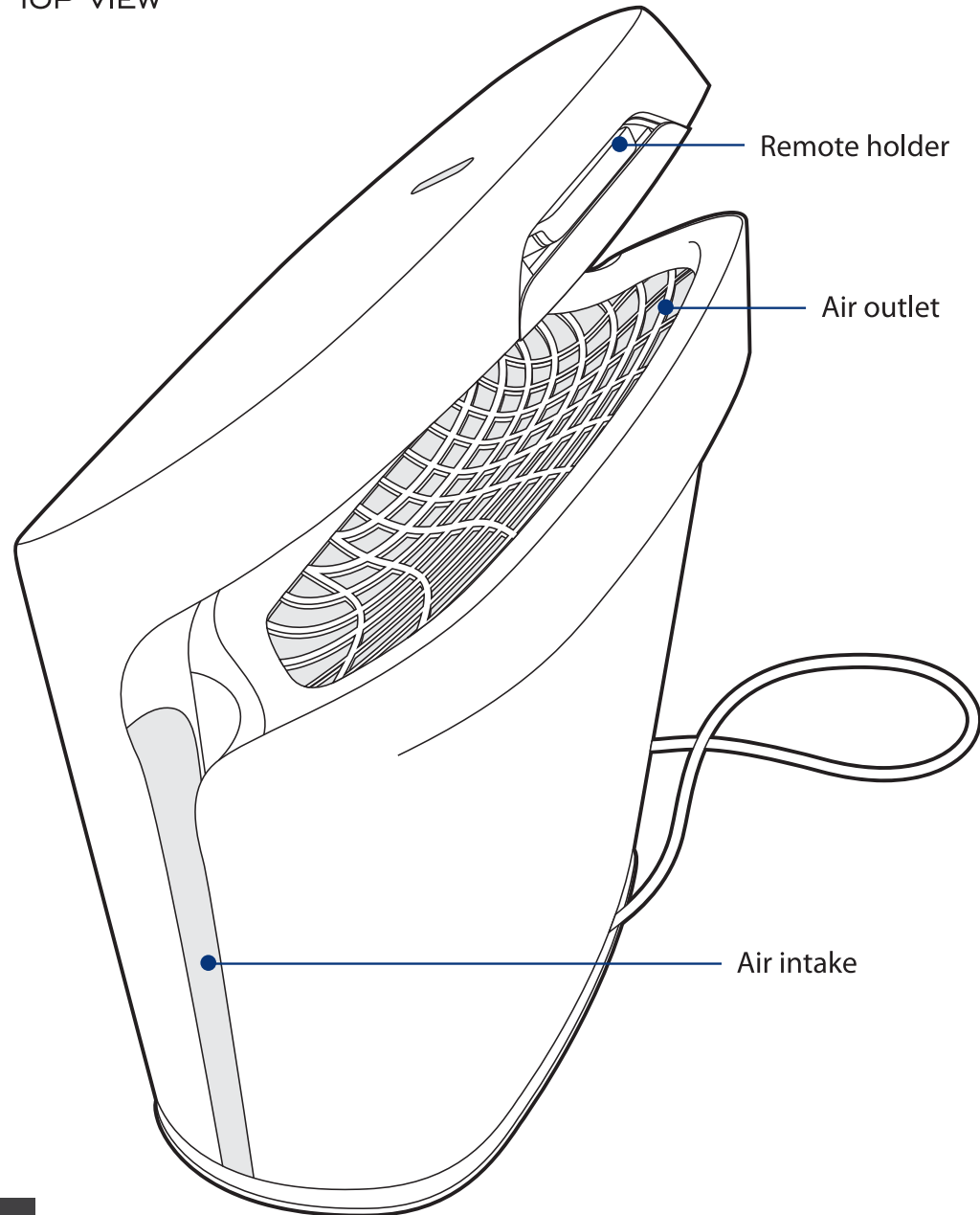

FRONT VIEW

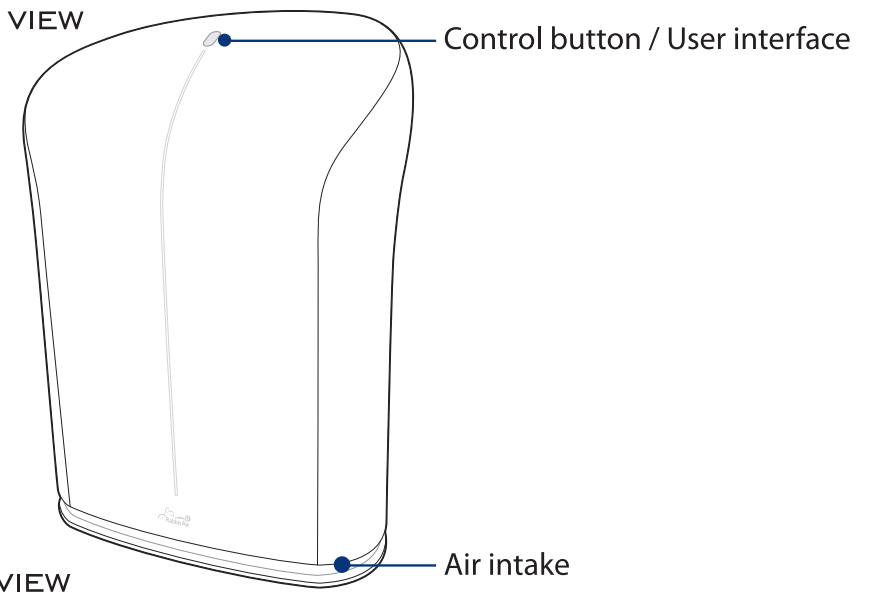

BACK VIEW

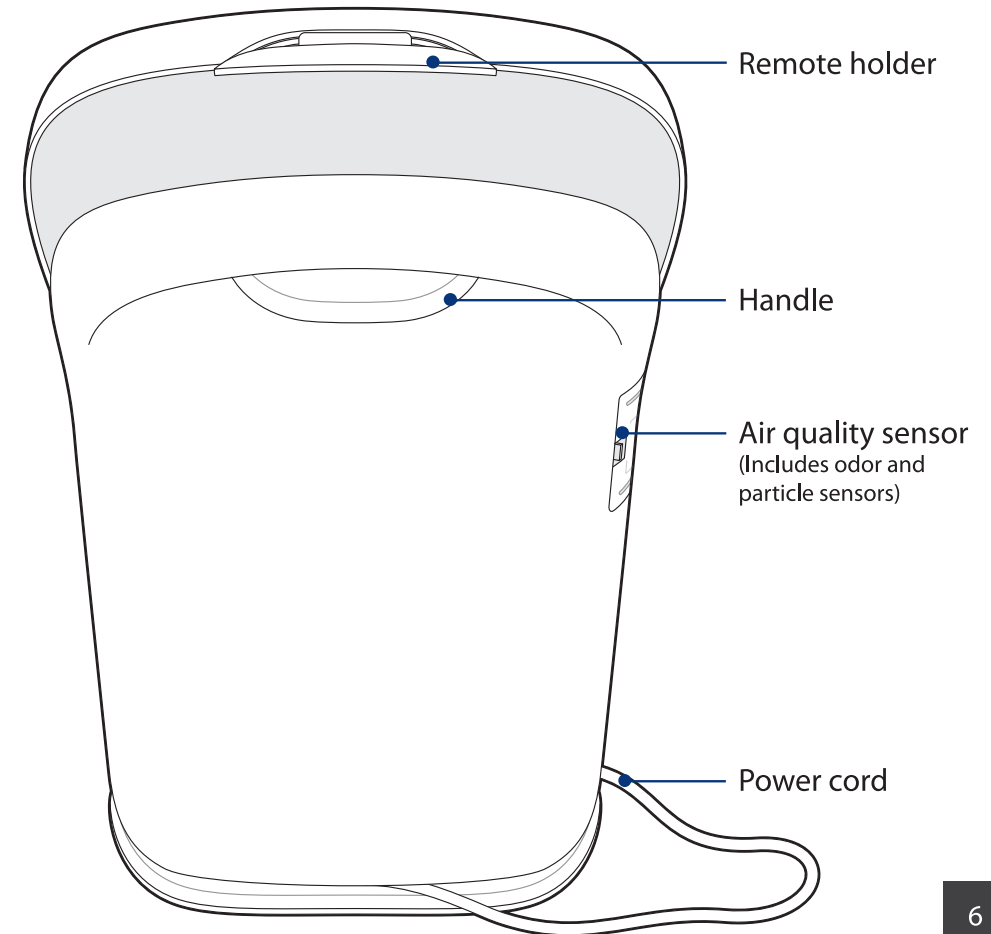

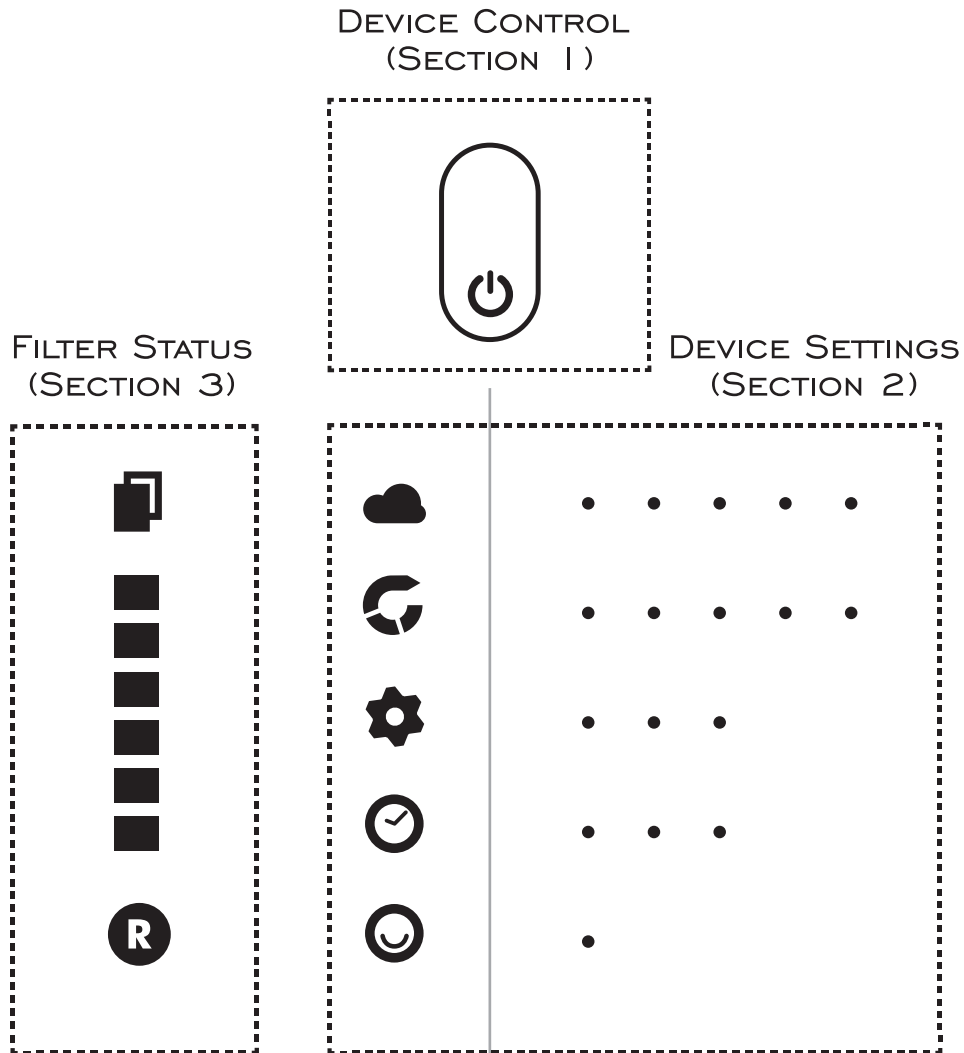

MAIN CONTROL BUTTON



The control button light will appear when the BioGS is operating.

Tap this button to power on the unit.

Tap it again to cycle through different fan speeds and auto modes.

Press and hold to power off the unit.

REMOTE CONTROL

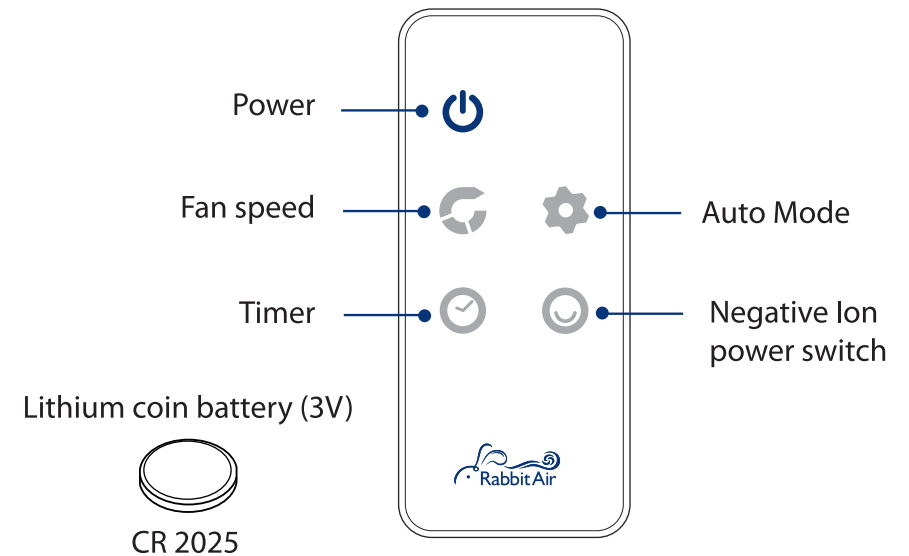

CR 2025



When the unit has been idle for five minutes, the user interface lights will disappear. To view the display, tap the control button on the unit or remote.



These lights indicate the level of air pollution detected.



These lights indicate the fan speed of the unit.



These lights indicate the sensitivity of the air quality sensor.



These lights indicate how long the timer has been set for.



This light illuminates if the Negative Ion Generator is on.



• **Air Quality Indicator**

When the air purifier is in Auto Mode, the Air Quality Indicator will continually monitor the odor and particle levels in the air, the user interface will light up briefly each time the pollution level changes. When the purifier is in a manual speed setting, the interface will not light up.



• **Fan Speed**

These lights indicate the current manual speed setting. Low fan speed is indicated by a single light. High fan speed is indicated by five lights. When in Auto Mode, the fan speed will adjust according to the air quality.

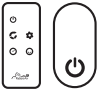

• **Auto Mode**

These lights indicate the level of sensitivity of the air quality sensor when the unit is in Auto Mode. The fan adjusts its speed according to the air quality.

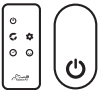

• **Timer**

Set the air purifier to turn off after a specific period of time. One light indicates a four-hour timer, two lights indicate an eight-hour timer, three lights indicate a 12-hour timer.



• **Negative Ions**

When this light is on, it means the unit is generating negative ions.



This feature can be accessed through the main control button.



This feature can be accessed through the remote.

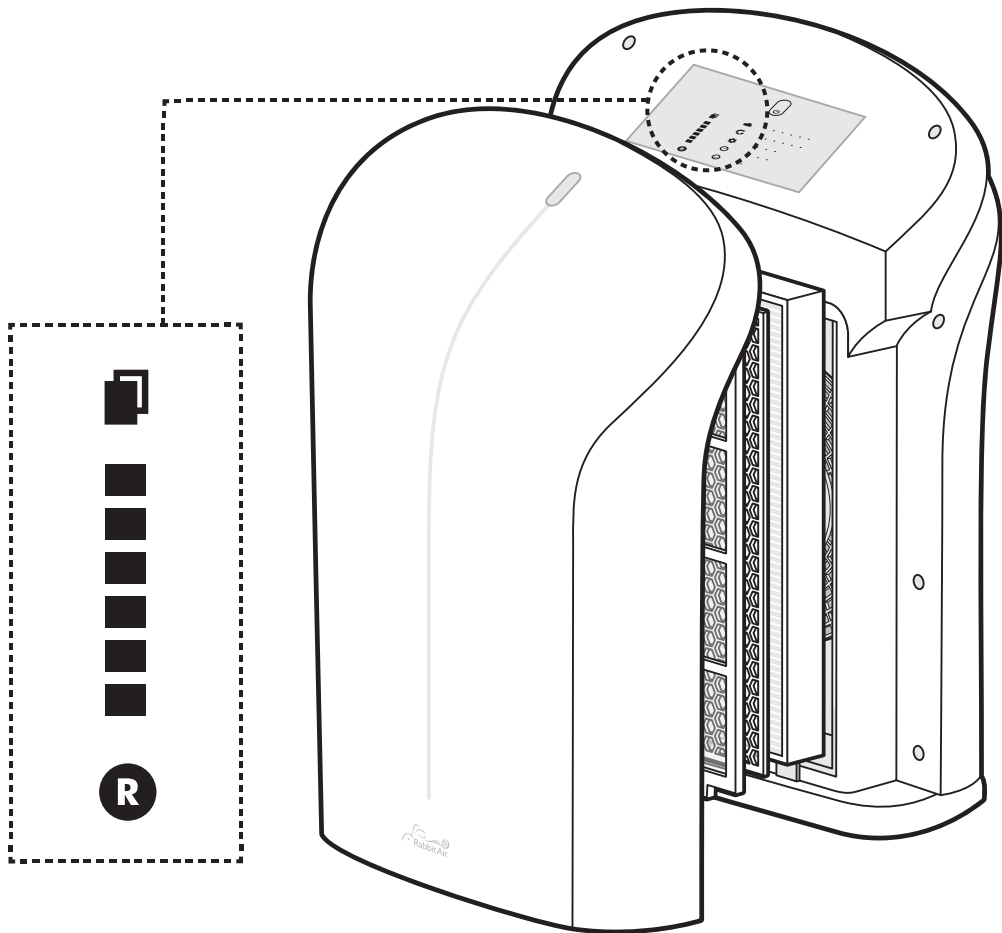

• **Filter Maintenance & Replacement Light**

The Filter Maintenance and Replacement Light will illuminate when your air purifier needs attention.

Solid light = It's time to clean the filters.
Flashing light = It's time to replace the filters.



• **Filter Life Light**

The Filter Life Light is visible only when the front panel has been removed. It indicates how much time has passed since the last time the filters were replaced. Since the filters should be cleaned every three months, each light represents three months of the filters' life. Each time a light goes out, the Filter Maintenance and Replacement Light will illuminate to inform you that it's time to clean the filters.

6 LEDs = The filters are new.
1 LED = The filters should be replaced soon.



• **Filter Reset Button**

Press this button briefly to turn off the Filter Maintenance and Replacement Light after each cleaning, the Filter Life Light will continue to diminish as time passes. We recommend replacing the filters every 18 months. After you have replaced them, press and hold for 5 seconds to reset the Filter Life Light.

MEET THE FILTERS

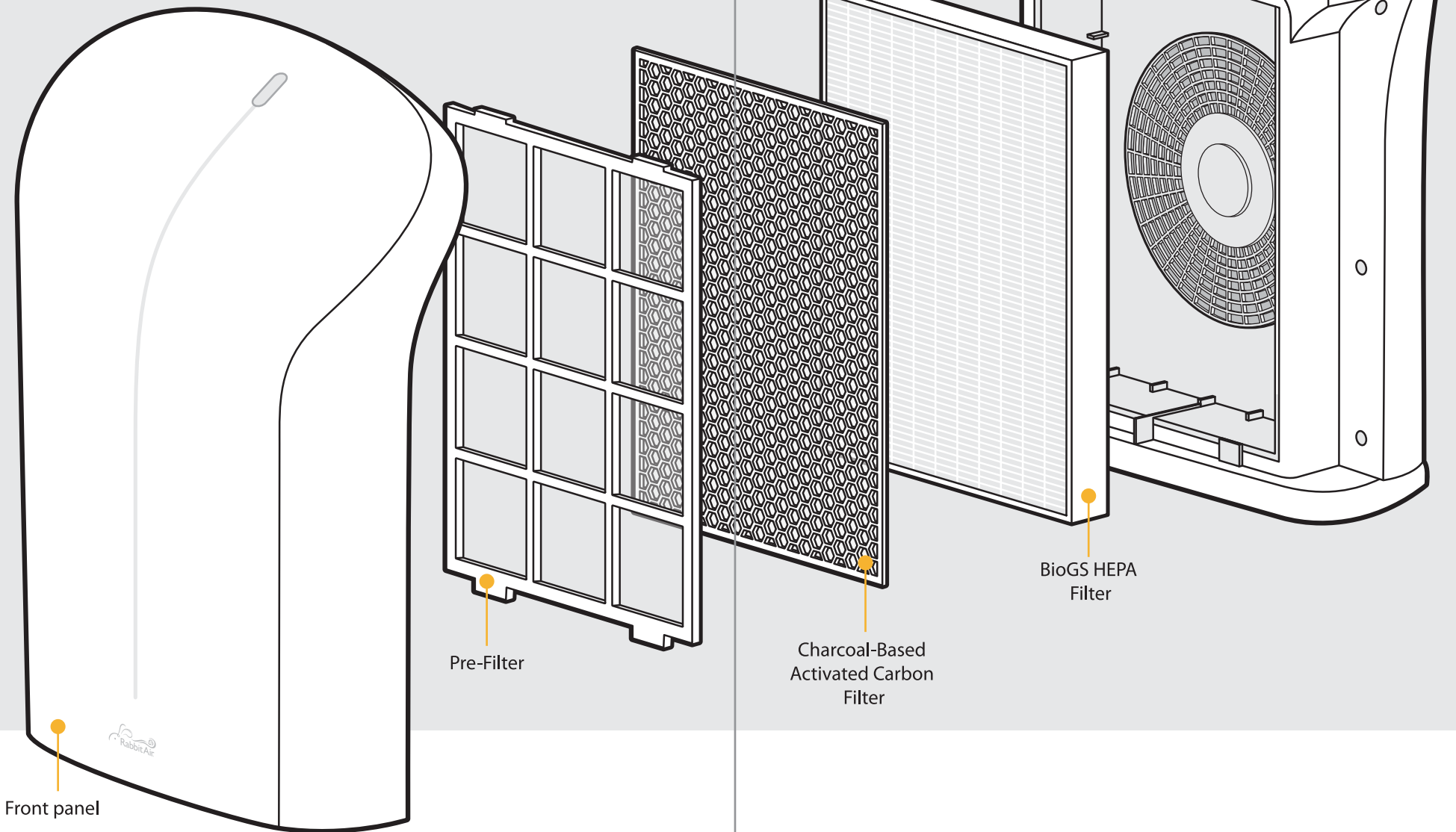

LET'S BEGIN - INITIAL SETUP

The BioGS Air Purifier is designed for residential use only. To maintain the quality of the filters, they are packaged in plastic. Please remove the filters from the plastic bags before using the unit.

1. Remove the front panel by lifting from the bottom and pulling up.

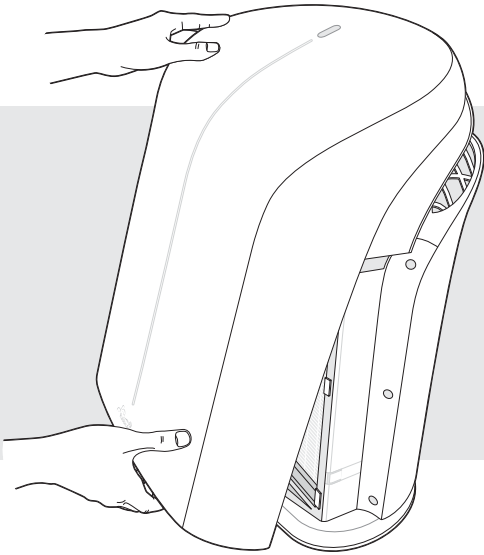

2. Pinch the two tabs on top of the Pre-Filter to remove it.

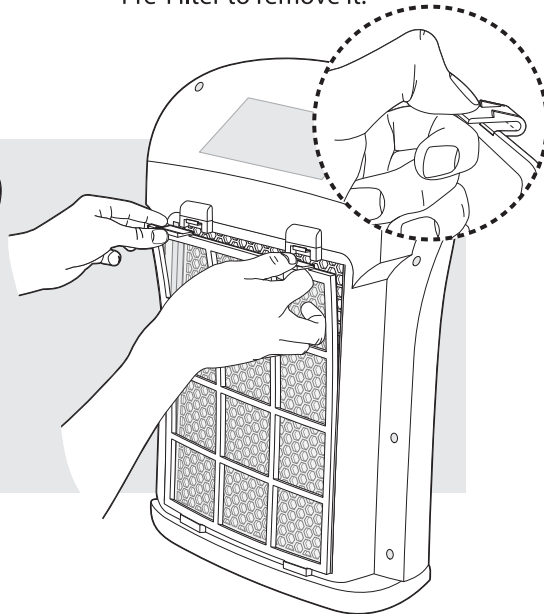

3. Pull out the Activated Carbon Filter and discard its plastic wrapping.

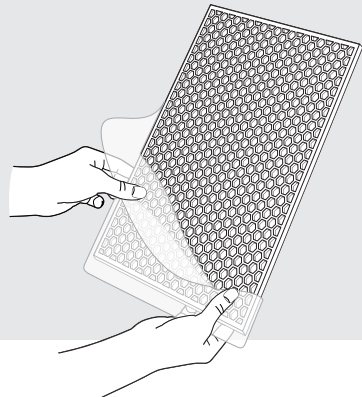
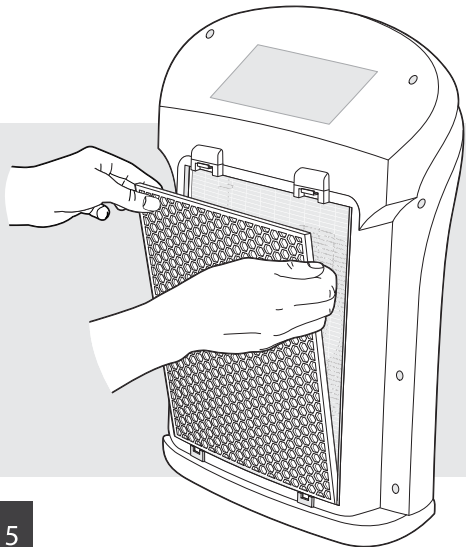

4. Remove the HEPA Filter and discard its plastic wrapping.

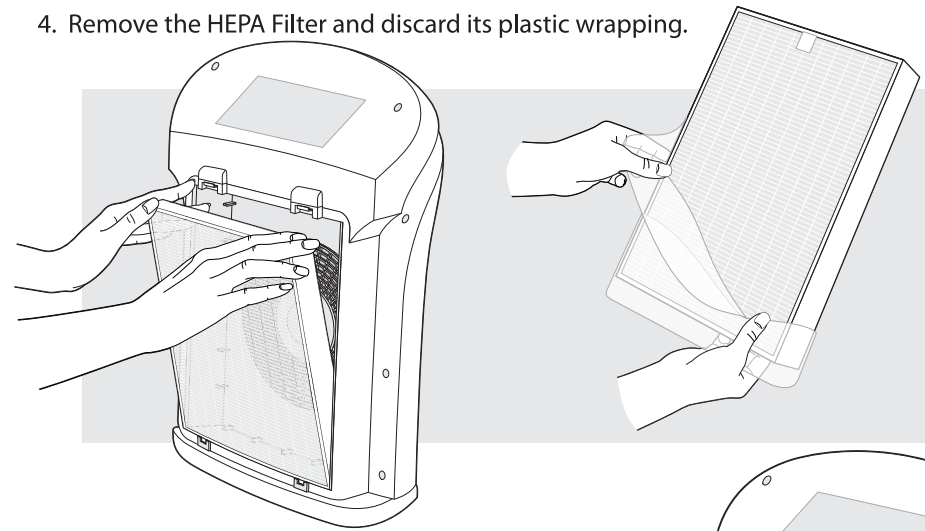

5. Return the filters to the filter case in the following order from back to front:

BioGS HEPA Filter
Activated Carbon Filter
Pre-Filter

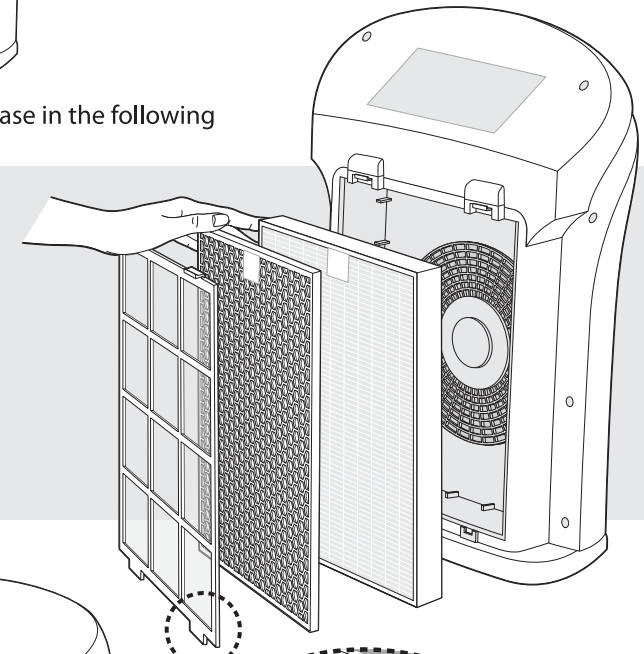

6. Reattach the front panel.

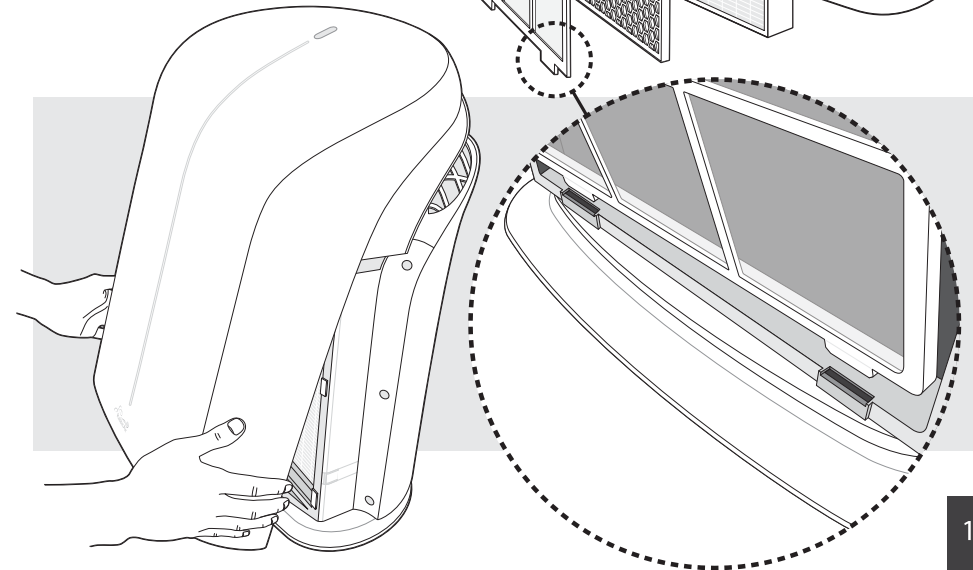

CLEANING AND MAINTENANCE

CLEANING THE AIR QUALITY SENSOR (Includes particle and odor sensors)

Clean the air quality sensor every six months or as needed.

1. Open the air quality sensor cover (on the right side of the unit).
2. Use a damp cotton swab to clean the lens, dust intake, and dust outlet, and dry thoroughly.

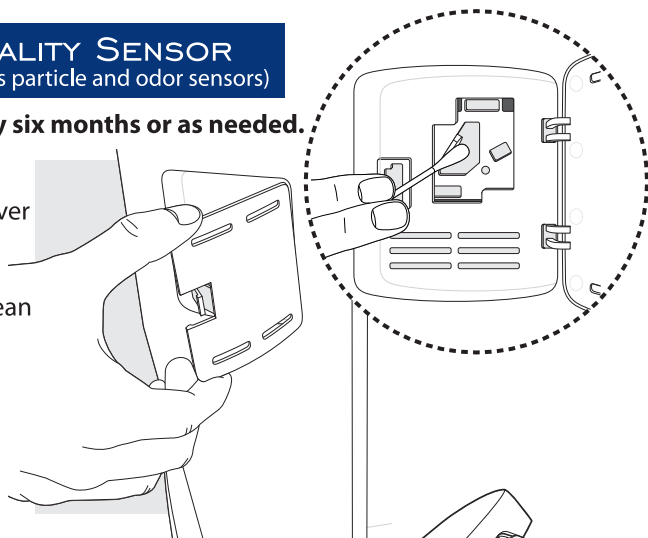

CLEANING THE AIR INTAKE AND OUTLET

1. Clean the air intake and outlet with a dry cloth or a soft brush. If necessary, use a damp cloth. Avoid commercial cleaning products.

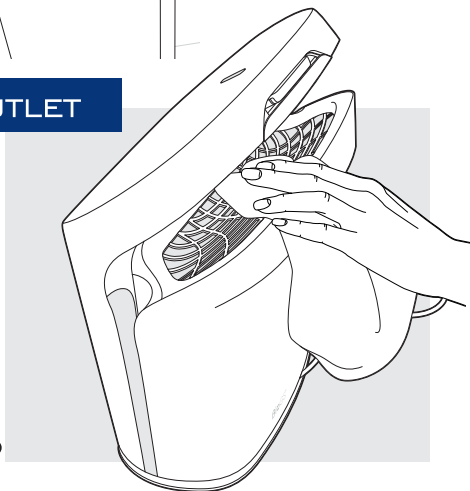

Caution: Be careful not to drop anything into the unit.

CLEANING THE FRONT PANEL AND UNIT SURFACE

1. Remove the front panel from the unit and use a dry cloth or soft brush to dust off the front and the back of the panel. If necessary, use a damp cloth to remove stubborn stains and dirty buildup. Avoid commercial cleaning products.
2. Use a clean, dry cloth to wipe the external surfaces of the air purifier.

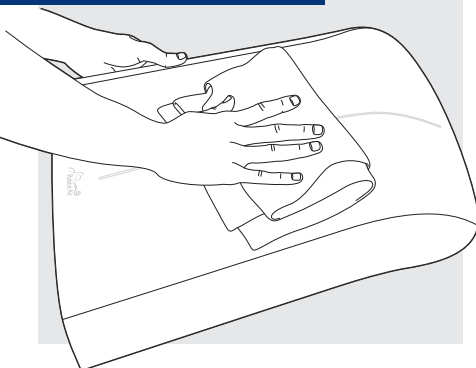

CLEANING THE PRE-FILTER

The Pre-Filter should be cleaned according to the level of pollution in the air of the room.

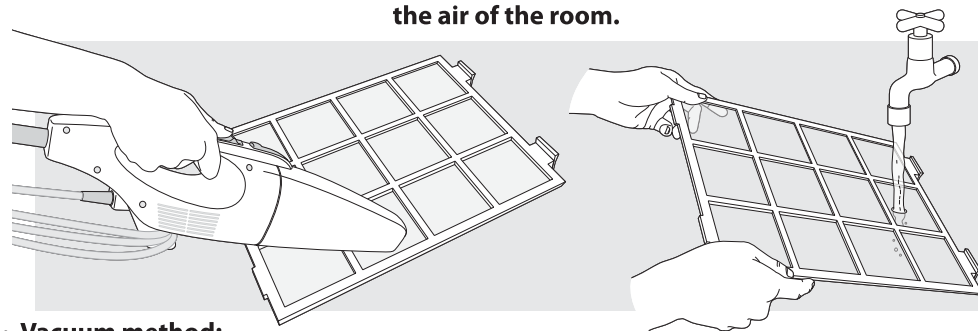

• Vacuum method:

1. Remove the front panel from the air purifier.
2. Run a handheld vacuum cleaner with a nozzle or brush attachment on a low power setting along the Pre-Filter to remove visible particles.

If vacuuming does not seem to sufficiently clean your Pre-Filter, please follow the steps below to wash it.

• Washing method:

1. Remove the Pre-Filter from the unit.
2. Fill the sink with lukewarm water and gently wash the Pre-Filter under the water for two to three minutes or until it is completely clean.
3. Rinse the Pre-Filter with clean tap water.
4. Use a towel to remove any excess water from the Pre-Filter.
5. Allow the Pre-Filter to dry for 12 to 24 hours.
6. When the Pre-Filter is completely dry, place it back into the air purifier.

CLEANING THE HEPA FILTER

• Vacuum method:

1. Run a handheld vacuum cleaner on low power setting, or a soft brush, along the HEPA Filter to remove visible particles.

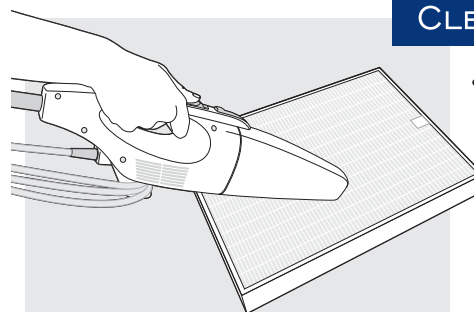

CLEANING THE ACTIVATED CARBON FILTER

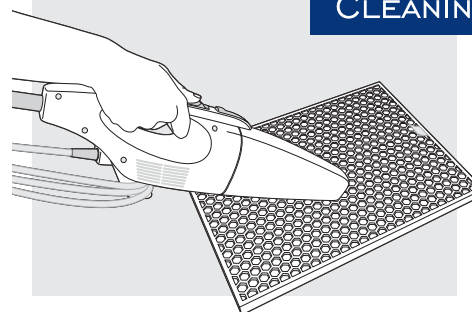

• Vacuum method:

1. Run a handheld vacuum cleaner with a nozzle or brush attachment on low power setting along the Activated Carbon Filter to remove visible particles.

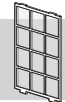

FILTER CLEANING AND REPLACEMENT SCHEDULE*

The lifespan of the filters is estimated based on normal residential use.

Filters	Filter life	Cleaning
 Pre-Filter	Permanent/Washable	Every month
 BioGS HEPA	18 Months	Every three months
 Charcoal-Based Activated Carbon	18 Months	Every three months

*Based on 24/7 operation

REPLACING THE FILTERS

Always unplug the unit before cleaning/replacing the filters.
The lifespan of the air purifier's filters will vary, based on the amount of pollutants in your home.

REPLACING THE PRE-FILTER PERMANENT FILTER

Do NOT discard the Pre-Filter. It is designed to be cleaned and reused.

The Pre-Filter is a permanent filter and does not need to be replaced.

1. Pinch the two tabs on top of the Pre-Filter to remove it.
2. Put the Pre-Filter aside while replacing the other filters.

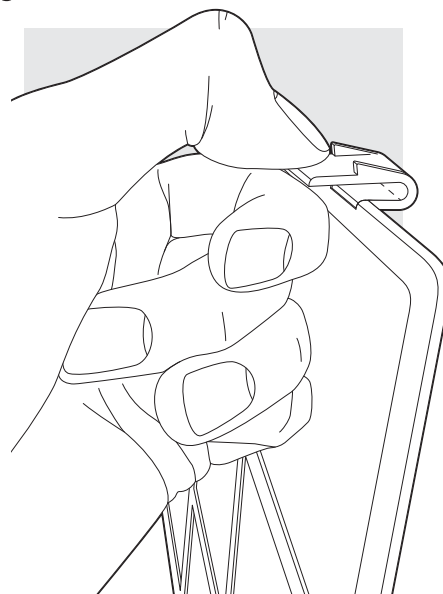

REPLACING THE ACTIVATED CARBON FILTER EVERY 18 MONTHS

Discard the old Activated Carbon Filter. This filter cannot be reused.

1. Pull out the old Activated Carbon Filter and discard.
2. Remove the new Activated Carbon Filter from its plastic wrapping and place in the BioGS unit.

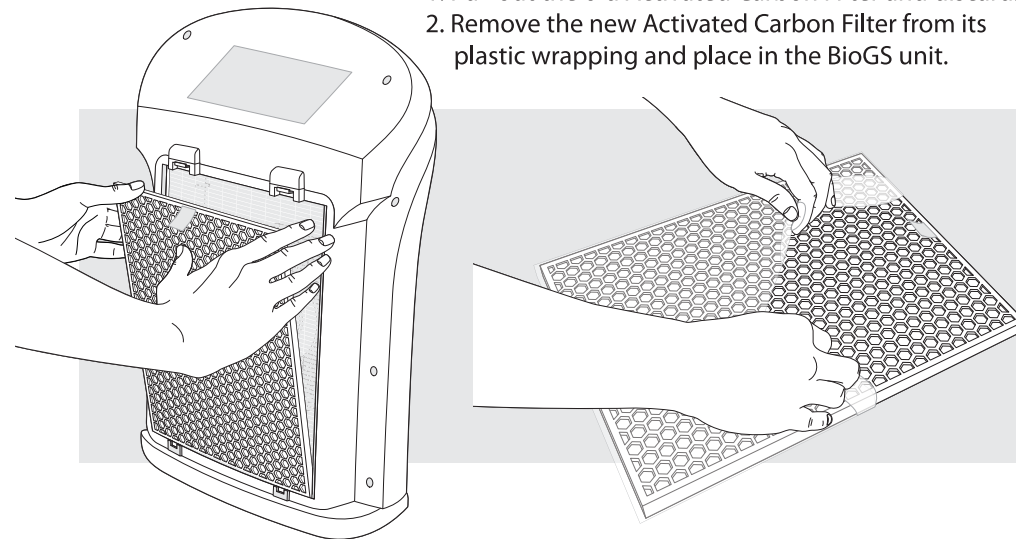

REPLACING THE BIOGS HEPA FILTER EVERY 18 MONTHS

Discard the old HEPA Filter. This filter cannot be reused.

1. Remove and discard the old HEPA Filter.
2. Remove the new filter from its plastic wrapping.
3. Place the new HEPA Filter in the BioGS unit.

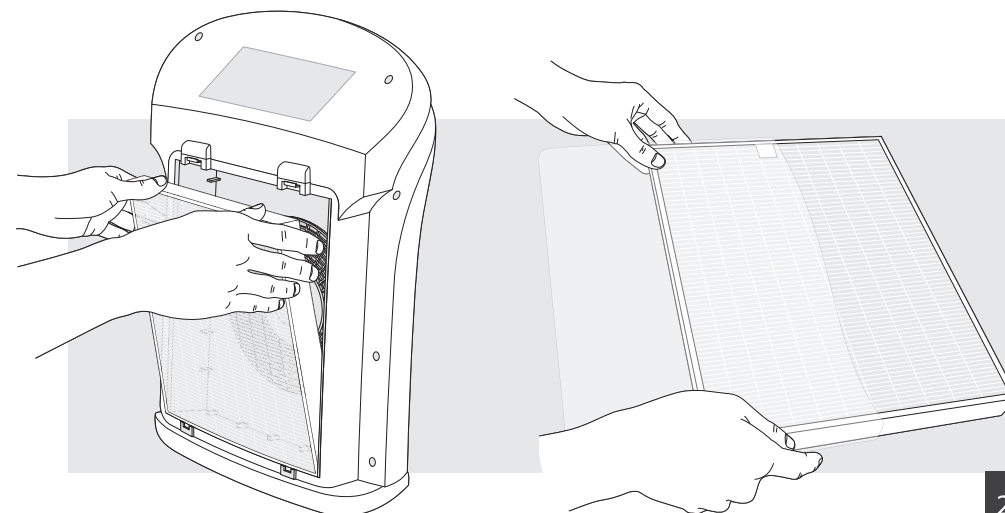

LIMITED WARRANTY

Rabbit Air warrants that your air purifier ("Product") will be free from defects in material or workmanship for a period of five (5) years from the date of purchase. To activate the warranty, please complete the warranty registration form online at www.rabbitair.com/warranty within 90 days of your air purifier purchase. To ensure product performance, the filters should be replaced with authentic Rabbit Air replacement filters as recommended in this manual ('Limited Warranty'). Within the first 90 days of purchase, Rabbit Air will replace the defective unit at no additional cost and reimburse any shipping charges. After 90 days, Rabbit Air's obligation and liability under this limited warranty is limited to repairing or replacing (at our sole discretion) the defective product. The limited warranty does not cover replacement filters. In the event of product malfunction or failure, please contact Rabbit Air to obtain a return authorization number and the address of the service center. The return authorization number must be clearly written on the outside of the shipping box or the shipment may be refused. This warranty extends only to the original purchasers who acquire new product from Rabbit Air, its subsidiaries, or its authorized resellers.

Rabbit Air will have no warranty obligation with respect to the following products ("Ineligible Products"): (i) Products that have no defects in materials or workmanship; (ii) Products with defects that are not reproducible by Rabbit Air; (iii) Products marked as "sample" or sold "AS IS"; or (iv) Products that have been subject to: (a) any modifications, alterations, repair, or servicing by any party other than Rabbit Air or Rabbit Air's authorized representatives, (b) handling, storage, installation, testing, or use not in accordance with the applicable Documentation, (c) abuse, negligence, neglect, accidents, abuse or misuse, (d) any breakdowns, fluctuations, or interruptions in electric power or connected to improper power supply, or (e) any Acts of God, including fire, flood, tornado, earthquake, hurricane, excessive snow, lightning, riot, insurrection, act of war, or other disaster.

LIMITS AND EXCLUSIONS

There are no express warranties except as listed above.

THE WARRANTOR SHALL NOT BE LIABLE FOR INCIDENTAL OR CONSEQUENTIAL DAMAGES RESULTING FROM THE USE OF THIS PRODUCT, OR ARISING OUT OF ANY BREACH OF THIS WARRANTY. ALL EXPRESS AND IMPLIED WARRANTIES, INCLUDING THE WARRANTIES OF MERCHANTABILITY, AND FITNESS FOR A PARTICULAR PURPOSE, ARE LIMITED TO THE APPLICABLE WARRANTY PERIOD SET FORTH ABOVE.

Some states do not allow the exclusion or limitation of incidental or consequential damages, or limitations on how long an implied warranty lasts, so the above exclusions or limitations may not apply to you. This warranty gives you specific legal rights and you may also have other rights which vary from state to state. If a problem with the product develops during the warranty period, we will repair or replace it without charge to you. A shipping fee may apply. To obtain service under warranty, please contact Rabbit Air at 1-888-866-8862 or by e-mail at CustomerService@rabbitair.com

Questions? Visit www.rabbitair.com to learn more.  24/7 CUSTOMER CARE

Speak with a Rabbit Air® Consultant at 888.866.8862. 24 hours a day

“

The Rabbit Air five-year warranty is a statement of our confidence in the quality of our products and an assurance that we stand behind that quality 100 percent of the time. Labor is included in our warranty; when warranty work is performed, Rabbit Air pays the bill.

”



Bio[®]
GS WARRANTY
REGISTER ONLINE AT WWW.RABBITAIR.COM/WARRANTY

REGISTER YOUR AIR PURIFIER ONLINE NOW FOR:

- **Product Protection**
By registering your product and purchase information, we can confirm the date of purchase to secure your warranty. This confirmation serves as security in the event that your original proof of purchase is lost, or in case your unit needs any servicing in the future.
- **Proof of Ownership**
Your model number, serial number, and other information will be kept in our files. Please complete and return this registration within 90 days from purchase in order to receive our 5-year limited warranty.

