

VTAC

Single Package Vertical Air Conditioning System

AVH 9,000-24,000 Btu/hr Installation Instructions & Owner's Manual

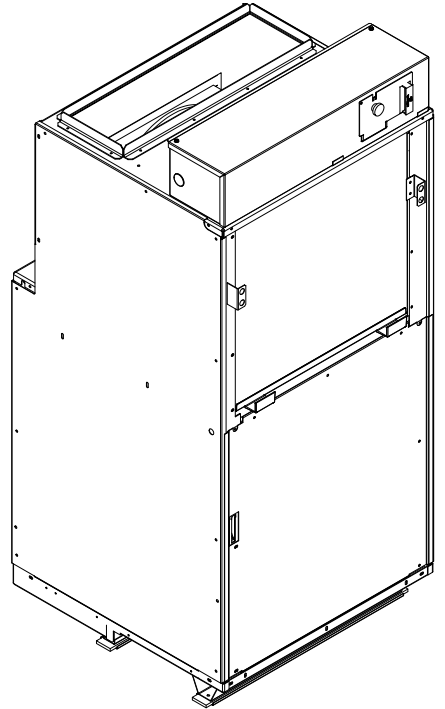
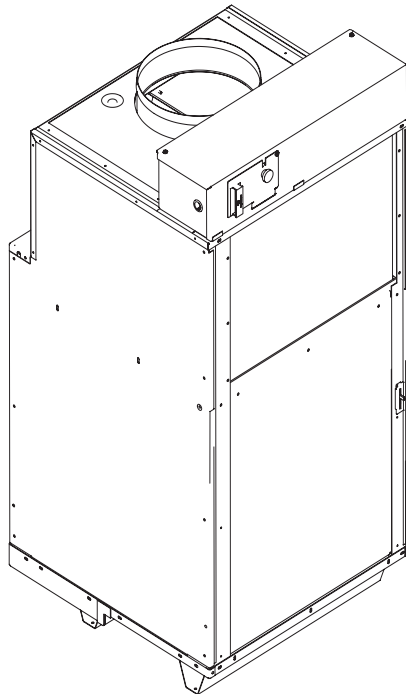
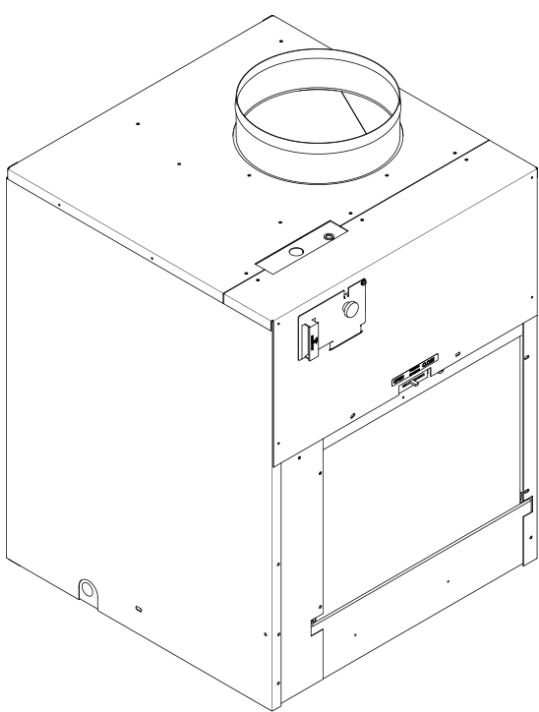

ATTENTION INSTALLING PERSONNEL

As a professional installer you have an obligation to know the product better than the customer. This includes all safety precautions and related items.

Prior to actual installation, thoroughly familiarize yourself with this Instruction Manual. Pay special attention to all safety warnings.

Often during installation or repair it is possible to place yourself in a position which is more hazardous than when the unit is in operation.



WARNING

Only personnel that have been trained to install, adjust, service or repair (hereinafter, "service") the equipment specified in this manual should service the equipment. The manufacturer will not be responsible for any injury or property damage arising from improper service or service procedures. If you service this unit, you assume responsibility for any injury or property damage which may result. In addition, in jurisdictions that require one or more licenses to service the equipment specified in this manual, only licensed personnel should service the equipment. Improper installation, adjustment, servicing or repair of the equipment specified in this manual, or attempting to install, adjust, service or repair the equipment specified in this manual without proper training may result in product damage, property damage, personal injury or death.

PROP 65 WARNING FOR CALIFORNIA CONSUMERS



WARNING

Cancer and Reproductive Harm -
www.P65Warnings.ca.gov

0140M00513-A

IO-914
01/2020

Amana is a registered trademark of Maytag Corporation or its related companies and is used under license to Goodman Company, L.P., Houston, TX, USA. All rights reserved.

5151 San Felipe, Suite 500 • Houston, TX 77056 • www.amana-ptac.com
© 2014 - 2015, 2017 - 2018 Goodman Company, L.P.



Contents

Electrical Data2
 Supply Air Flow Data.....3
 Control.....3
 VTAC Required Minimum Clearances.....3
 Installation Overview and Dimensional Data4
 Closet View.....4
 Exterior Wall Adapter Installation.....5
 Louver Installation.....6
 Final Wall Adapter and Architectural Louver Installation.....7
 Primary Drain Connection and Location.....8
 Drain Pan Installation AVH18 & AVH24.....8
 Indoor Return Air Grille and Ductwork Installation.....12
 Ductwork.....12
 Chassis Installation.....12
 Remote Thermostat and Low Voltage Control
 Connection.....13
 Final Installation Checklist.....14
 Chassis Operation.....14
 Chassis Final Connections.....14
 Service & Warranty.....14
 Routine Maintenance.....15
 Warranty.....15
 Electronic Control Error Code Diagnostics and
 Test Mode.....15
 ERROR CODES AND ALARM STATUS.....16
 Obtaining Service.....20

Important Note to the Owner

This manual is to be used by qualified, professionally trained HVAC technicians only. Goodman does not assume any responsibility for property damage or personal injury for improper service procedures or services performed by an unqualified person.

IMPORTANT NOTES:

Your warranty certificate is also supplied with the unit. Read the warranty carefully and note what is covered. Keep the warranty certificate in a safe place, so you can find it, if necessary.

Before using this manual, check the serial plate for proper model identification.

THE INSTALLATION AND SERVICING OF THIS EQUIPMENT MUST BE PERFORMED BY QUALIFIED, EXPERIENCED TECHNICIANS ONLY.

Due to policy of continual product improvement, the right is reserved to change specifications and design without notice.

Remember, it is your responsibility to install the product safely and to know it well enough to be able to instruct a customer in its safe use.



Safety is a matter of common sense...a matter of thinking before acting. Most dealers have a list of specific good safety practices...follow them.

The precautions listed in this Installation Manual are intended as supplemental to existing practices. However, if there is a direct conflict between existing practices and the content of this manual, the precautions listed here take precedence.

Important Note to the Servicer

Read this manual and familiarize yourself with the specific items which must be adhered to before attempting to service this unit. The precautions listed in this Installation Manual are intended as supplemental to existing practices. However, if there is a direct conflict between existing practices and the content of this manual, the precautions listed here take precedence.

 **RECOGNIZE THIS SYMBOL AS A SAFETY PRECAUTION.**

 WARNING
<p>HIGH VOLTAGE DISCONNECT ALL POWER BEFORE SERVICING OR INSTALLING THIS UNIT. MULTIPLE POWER SOURCES MAY BE PRESENT. FAILURE TO DO SO MAY CAUSE PROPERTY DAMAGE, PERSONAL INJURY OR DEATH.</p> 

Electrical Data

Electrical Requirements	
Wire Size	Use ONLY wire size recommended for single outlet branch circuit.
Fuse/Circuit Breaker	Use ONLY type and size fuse or HACR circuit breaker indicated on unit's rating guide. Proper over current protection to the units is the responsibility of the owner.
Grounding	Unit MUST be grounded from branch circuit to unit, or through separate ground wire provided on permanently connected units. Ensure that branch circuit or general purpose outlet is grounded.
Wire Sizing	Use recommended wire size given in tables and install a single branch circuit. All wiring must comply with local and national codes. NOTE: Use copper conductors only.

Electrical Rating Table



NOTE: Use copper conductors **ONLY**. Wire sizes are per NEC.

Recommended Branch Circuit Sizes*	
Nameplate Maximum Circuit Breaker Size	AWG Wiring Size**
15A	14
20A	12
30A	10

AWG - American Wire Gauge

* Single circuit from main box.

** Based on 100' or less of copper, single insulated conductor at 60° C

 WARNING	
<p>HIGH VOLTAGE DISCONNECT ALL POWER BEFORE SERVICING OR INSTALLING THIS UNIT. MULTIPLE POWER SOURCES MAY BE PRESENT. FAILURE TO DO SO MAY CAUSE PROPERTY DAMAGE, PERSONAL INJURY OR DEATH. DO NOT SERVICE THIS UNIT WITHOUT FIRST SHUTTING OFF POWER TO THE UNIT FROM THE CIRCUIT BREAKER AND/OR REMOVING THE UNIT CORD SET PLUG FROM THE WALL OUTLET.</p>	

NOTE: All 230/208 chassis must be hard wired with a properly sized breaker. See unit nameplate for specific electrical requirements. Use HACR type breakers to avoid nuisance trips. All field wiring must be done in accordance with NEC and local codes. It is the installer's responsibility to ensure that the electrical codes are met.

Supply Air Flow Data
Indoor CFM & External Static Pressure

	Model			
	AVH09/AVH12		AVH18	
Fan Speed	Low	High	Low	High
ESP (")	CFM			
.10"	430	490	600	750
.15"	410	470	550	720
.20"	360	440	510	680
.25"	310	400	460	650
.30"	260	350	420	600

Indoor air flow may be determined by measuring the external static pressure (ESP) of the duct system using an inclined manometer or magnahelic gauge and consulting the above chart to derive actual air flow. Under no circumstances should the small chassis VTAC equipment be operated at an external static pressure in excess of .3" W.C. Operation of the VTAC under these conditions will result in inadequate air flow, leading to poor performance and/or premature component failure.

Control

For LOW speed only operation, connect the fan output terminal from the thermostat to the GL terminal of the electronic control.

For HIGH speed only operation, connect the fan output terminal from the thermostat to the GH terminal of the electronic control.

For thermostats with two-speed capability, connect the LOW speed output to the GL terminal and the HIGH speed output to the GH terminal.

VTAC Required Minimum Clearances

Building Exterior Unit Opening Requirements

VTAC units must be installed on an outside wall. Confined spaces and/or covered areas should be avoided. Units must be installed no closer than 12" apart when two units are side by side. If three or more units are to operate next to one another, maintain a minimum of 60" between units or pairs of units (Figure B). If more than two units are sharing a floor with adjacent, outset units, a minimum distance of 64" must be kept between units (Figure C). Also, a vertical clearance of 60" must be maintained (Figure A) between units. Units installed on the bottom floor must be mounted at least 6" off of the ground.

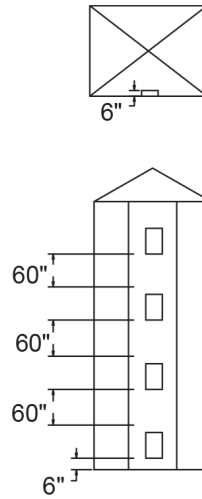

Figure A

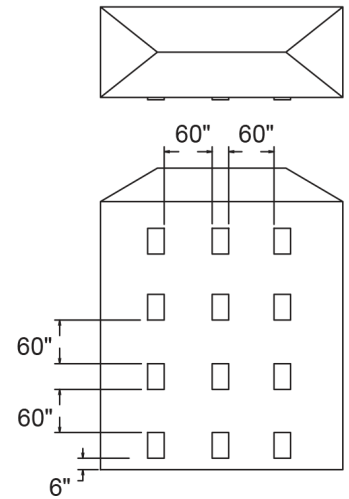

Figure B

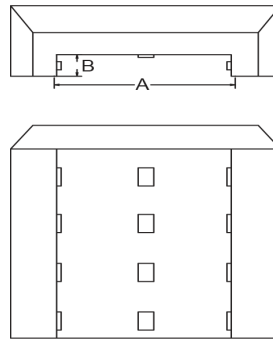

Figure C

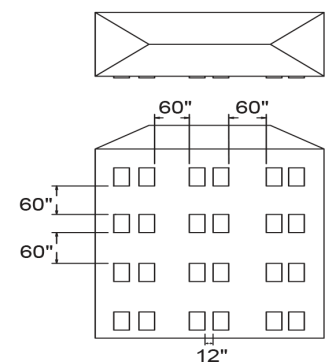

Figure D

Grill Clearance Requirements

Where obstructions are present use the following guidelines for proper spacing from the VTAC exterior louvered grill. Amana recommends that ALL obstructions are a minimum of 72" from the exhaust.

For minor obstruction(s) such as lamp poles or small shrubbery, a clearance of 24" from the outdoor louver must be maintained.

For major obstructions such as a solid fence, wall, or other heat rejecting devices like a condensing unit, a minimum distance of 72" must be kept.

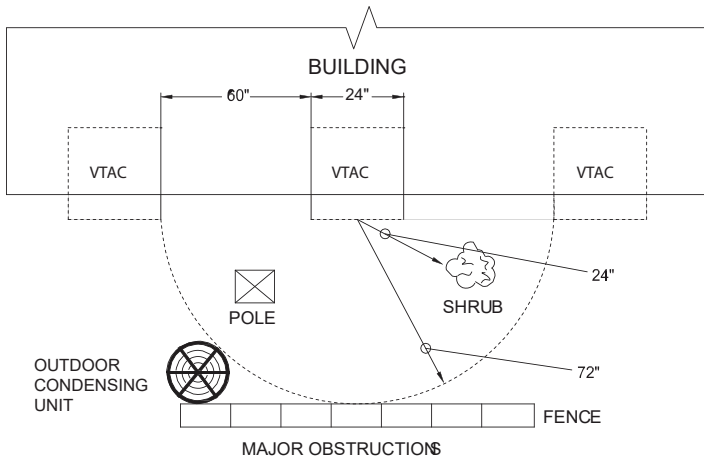

NOTE: The example pictured above is for reference only and does not represent all possible installations.

Installation Overview and Dimensional Data

Dimensions

AVH09 / AVH12 Chassis Dimensions (W x D x H)	23 1/8" x 23 1/8" x 32 1/4"
AVH18 Chassis Dimensions (W x D x H)	23 1/8" x 23 1/8" x 47 15/16"
AVH24 Chassis Dimensions (W x D x H)	23 1/8" x 23 1/8" x 51 7/8"
Exterior Rough Opening (W x H)	24 5/8" x 30 7/8"
Closet Rough Opening (W x H)	27" x 55 3/4"

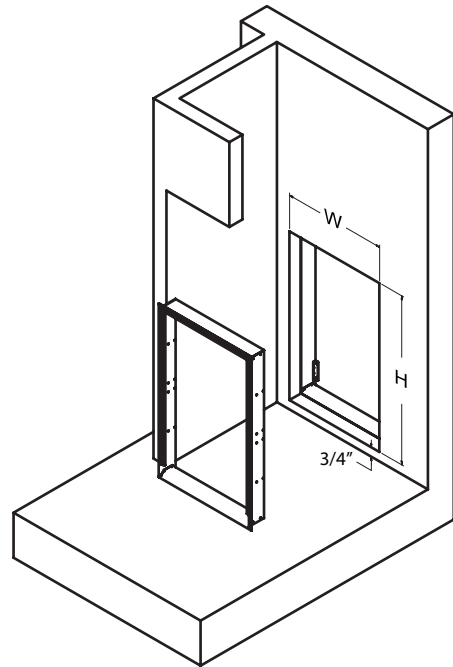

Exterior Wall Adapter Cut-Out Dimensions (W x H): 24 5/8" x 30 7/8"

NOTE: The distance between the rough opening and the finished floor/platform must be 3/4". If the installation will utilize an auxiliary drain pan, it may not exceed 3/4" in height.

Closet View

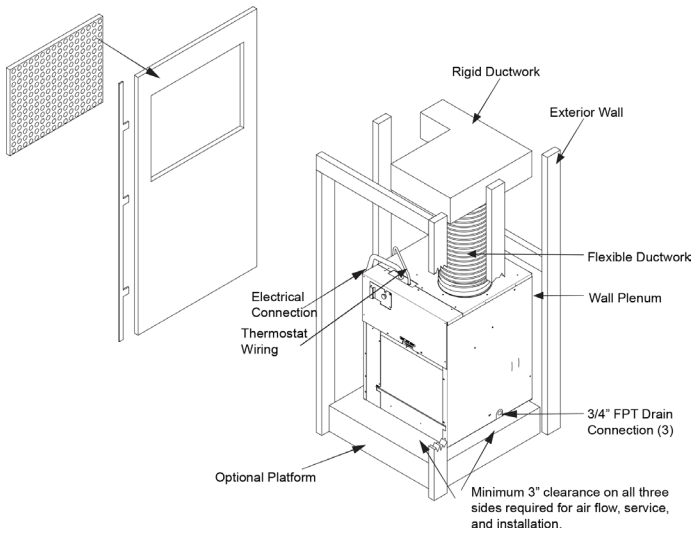

NOTE: It is recommended that 6" of clearance is provided on the side where the primary condensate is plumbed.

CLOSET INSTALLATIONS

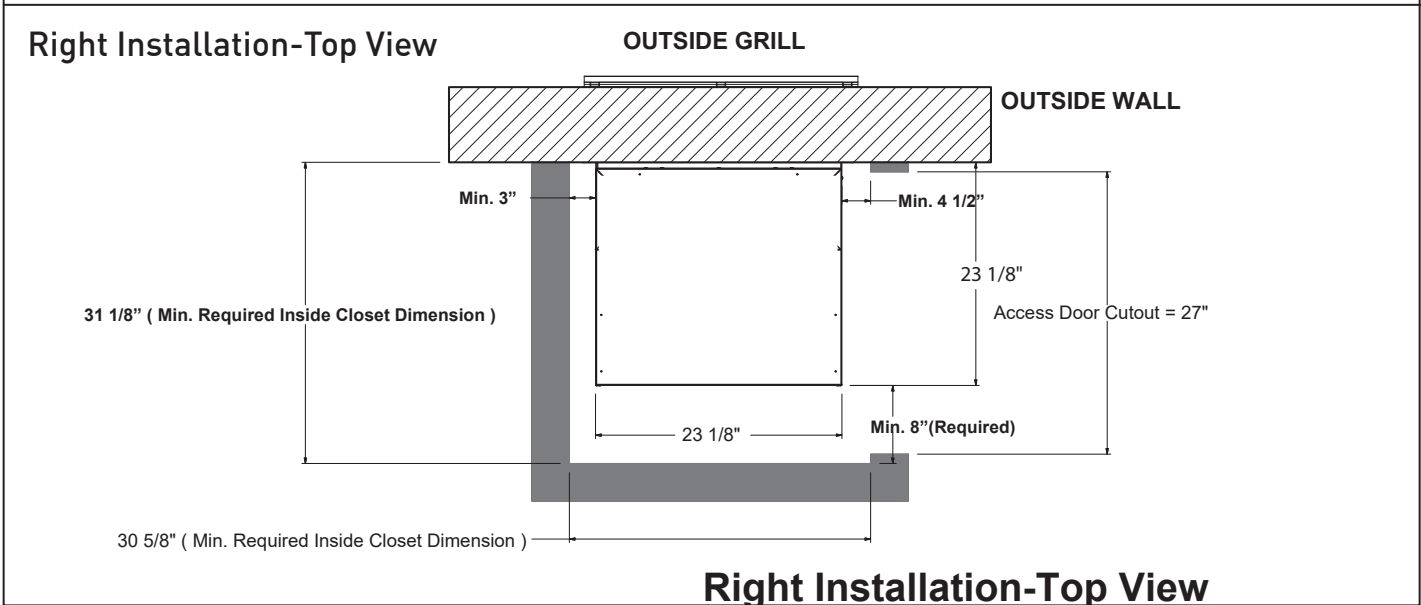
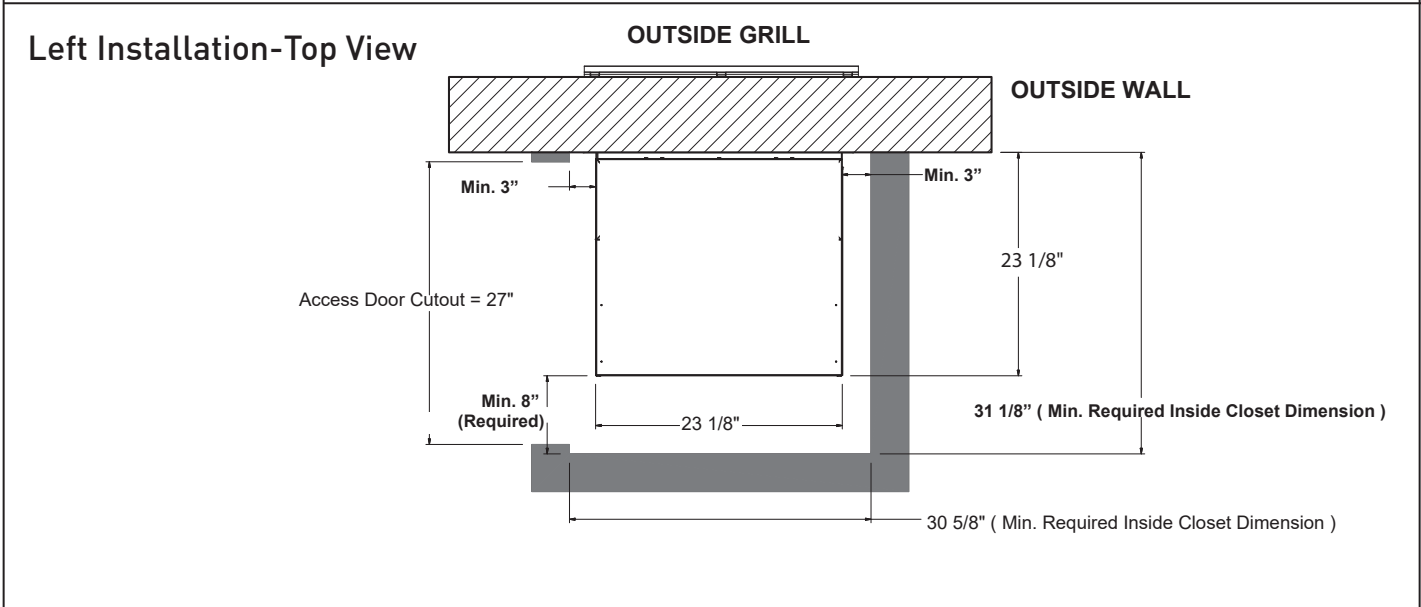
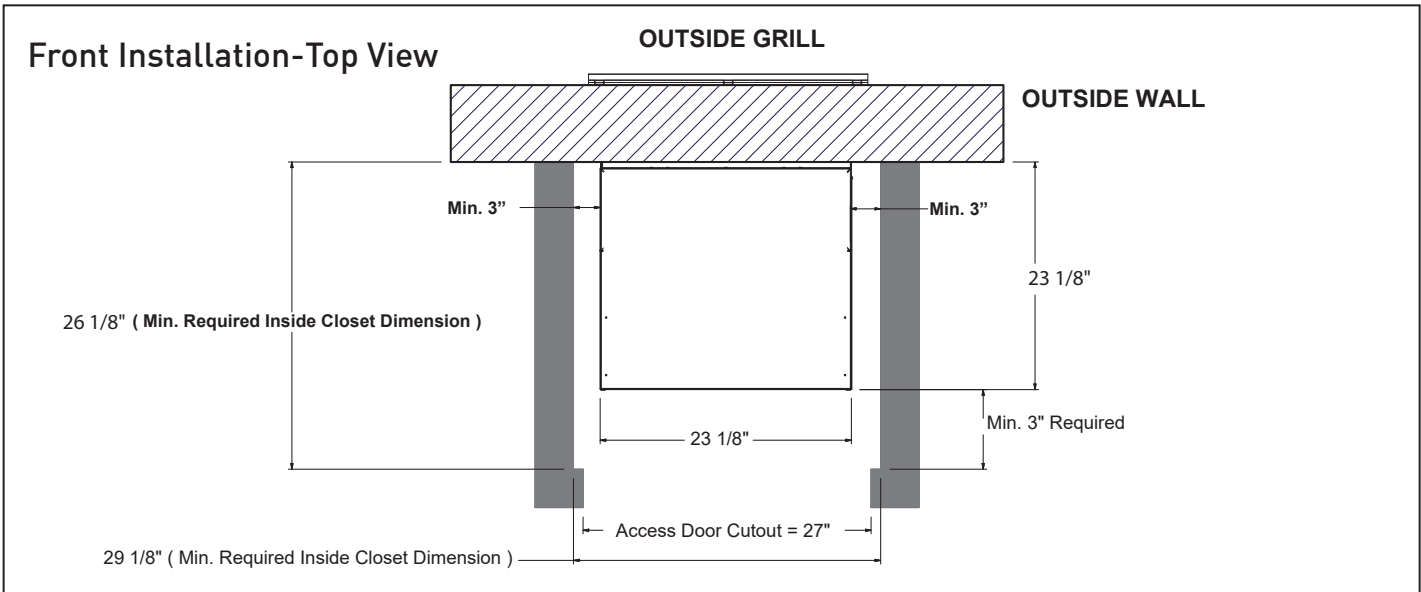

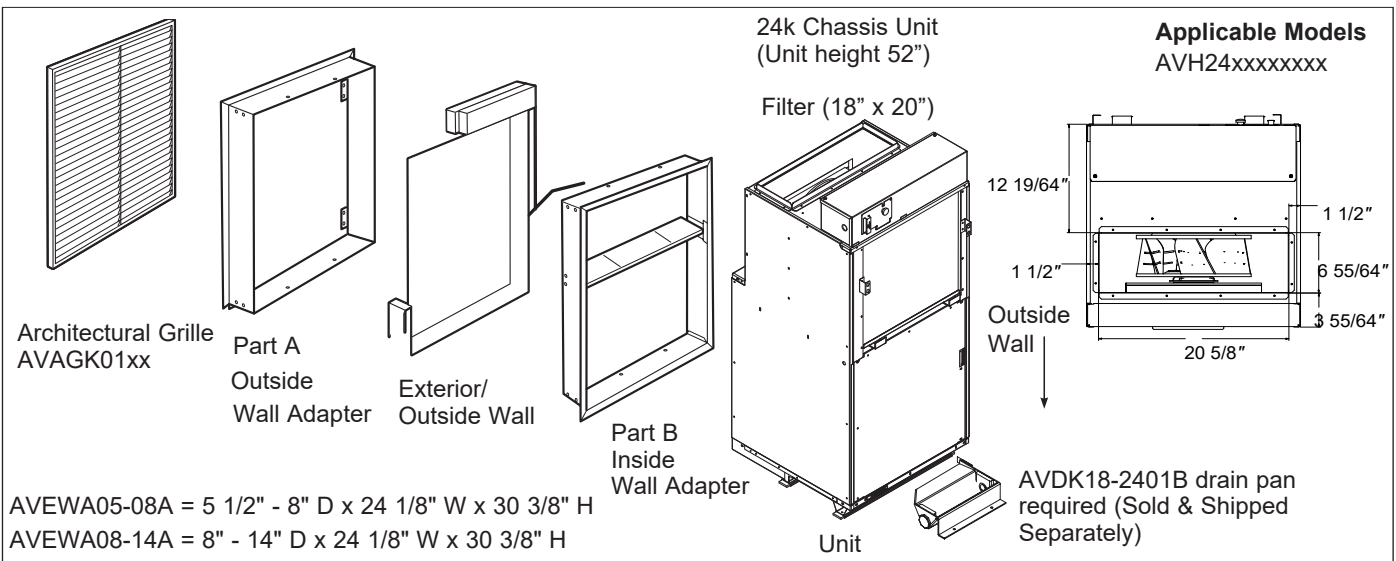
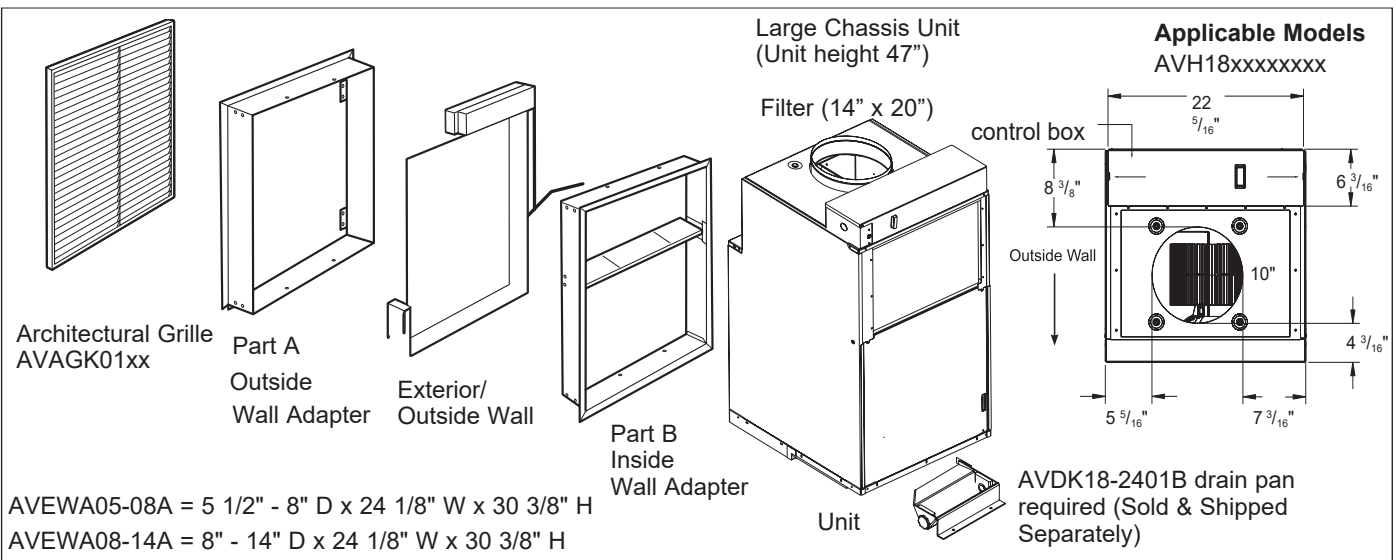
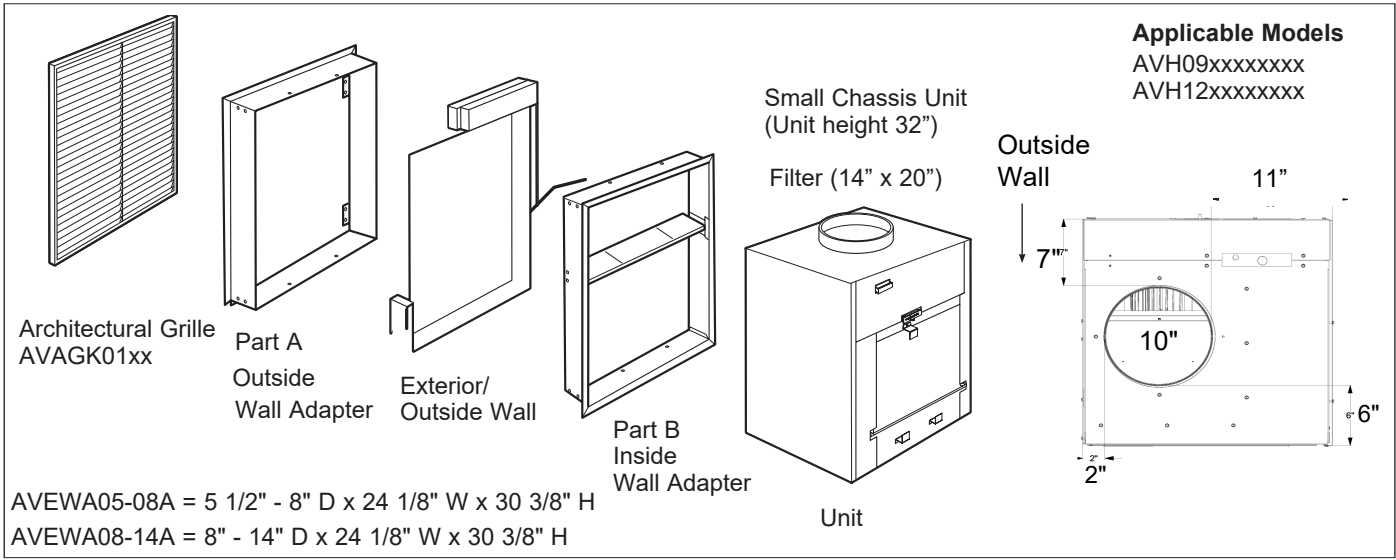

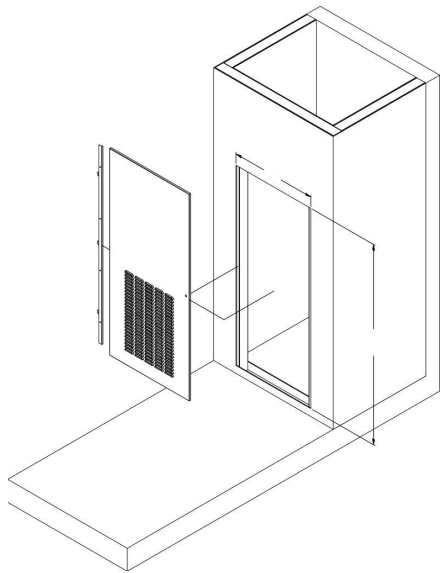

Return Air Access Door Wall Cut-Out
Dimensions (W x H): 27" x 55 3/4"

Field Supplied Parts:

Sealant, attachment screws, and flashing are field supplied. Silicone sealant is recommended.

AVEWA05-08A adjust for walls up to 4" - 8" thick.

AVEWA08-14A adjust for walls up to 8" - 14" thick

All installations are similar.

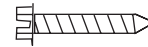
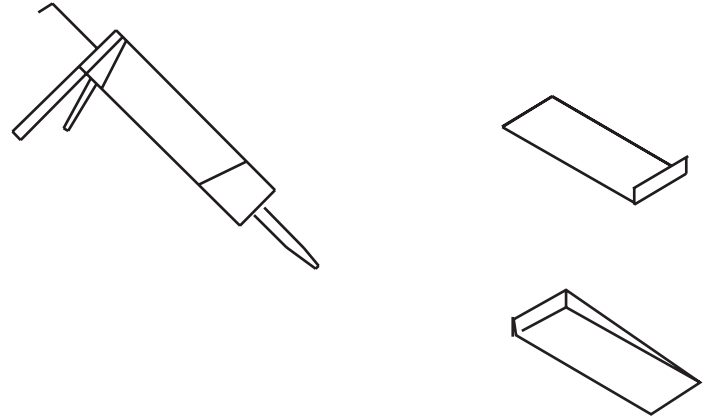

Wall Adapter Installation

Parts included in Wall Adapter Kit:

- Outside Adapter Half (Part A)
- Inside Adapter Half (Part B)

Step 1 - Outside Wall Adapter Half

NOTE: The Wall Adapter is not designed to carry any structural load. A load bearing header must be built above the rough opening.

1. Prepare the rough opening. The rough opening should be lined with metal or wood. The Wall Adapter will warp if sealed against concrete or brick.
2. Dry fit the outside Wall Adapter half into the rough opening and check the fit and level.
3. Remove the outside Wall Adapter half, flash the rough opening to ensure proper fit and level.
4. Pre-installing the exterior louver (AVAGK01CB) as shown above is optional (See Page 6).
5. Apply sealant to the outside Wall Adapter half and insert into the rough opening to ensure a water-tight seal. Ensure that the outside Wall Adapter half is securely attached to the framed opening.

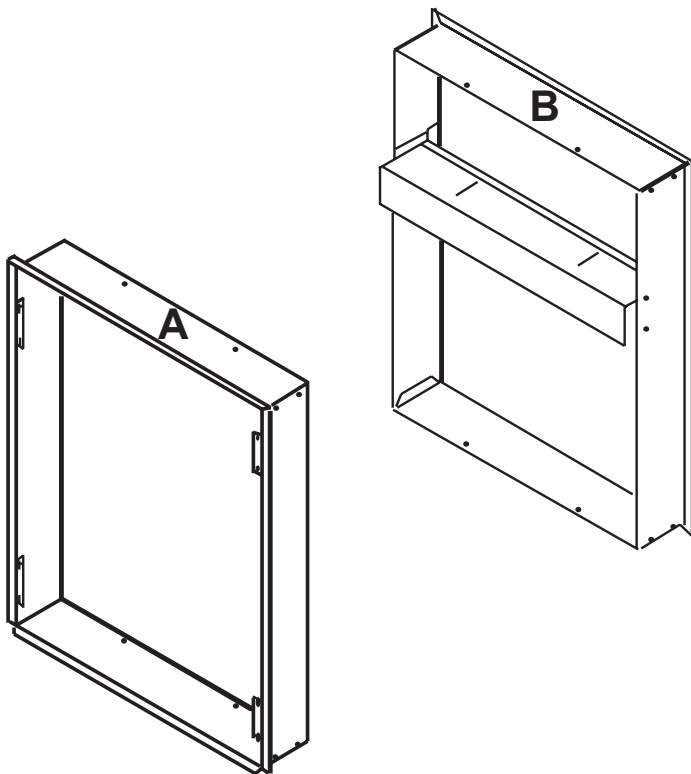

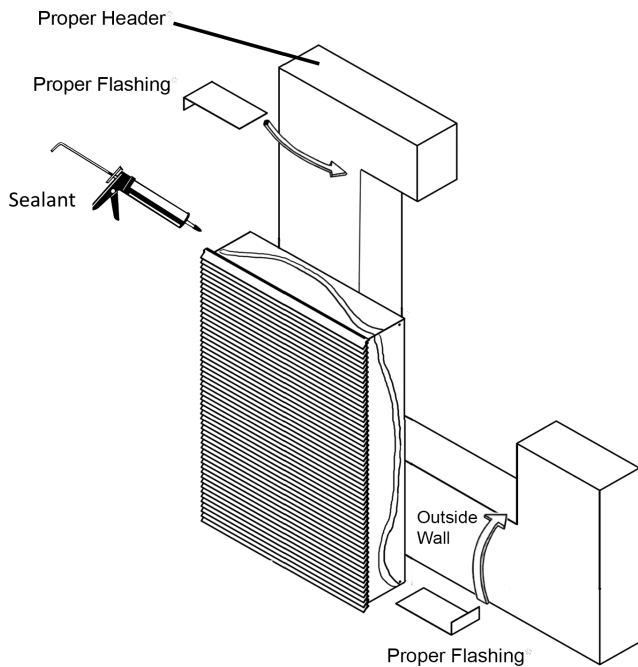

Step 3 - Inside Wall Adapter (cont.)

NOTE: Do not place any screws, fasteners, or penetrating holes through the top or bottom of the Wall Adapter assembly.

1. Drill pilot holes on the interior of the inside Wall Adapter half (Part B) as show in Detail B. Pilot holes should be located approximately 4" from the top and bottom of the inside Wall Adapter half, on both the left and right sides.
2. Install fasteners through each pilot hole. Fastener must pass through both Part A and Part B. If the inside and outside Wall Adapter halves do not overlap at fastening point, be certain to drill extra holes where needed to secure both Part A and Part B to the rough opening.

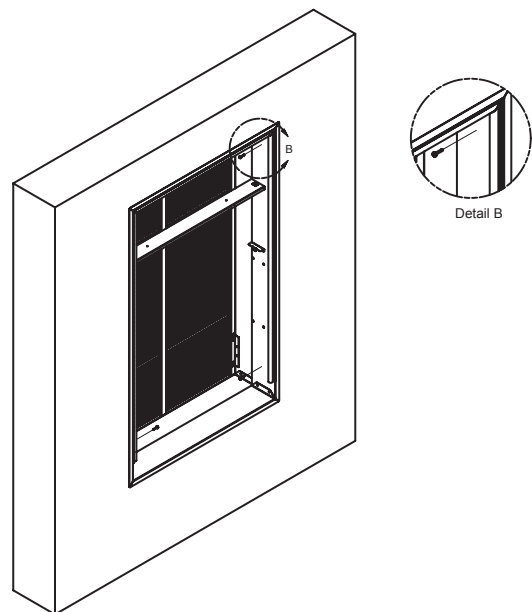

Step 2 - Inside Wall Adapter Half

1. Apply sealant to all 4 flange corners and unused holes. See Detail A.
2. Flash the inside of the rough opening to ensure the proper fit and level.
3. Insert inside Wall Adapter half (Part B) into outside Wall Adapter half (Part A). Ensure that Part A does not back out of the rough opening.
4. Remove the inside Wall Adapter half.
5. Apply sealant to the outside Wall Adapter half and insert into the rough opening to ensure a water-tight seal.

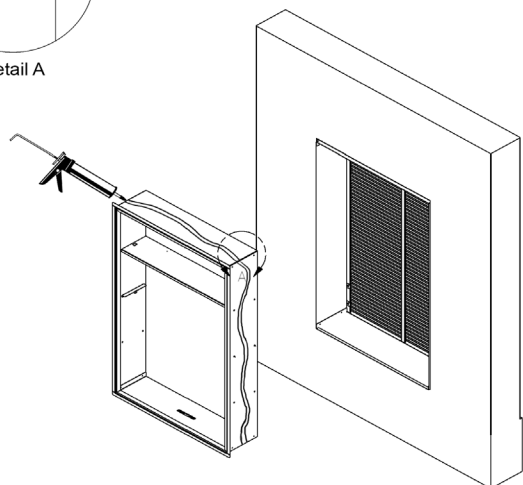
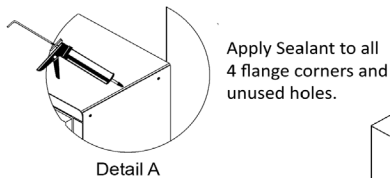

Louver Installation

Installation of the louver PRIOR to Wall Adapter installation

1. Hold the louver up to the outside Wall Adapter half (Part A) and line up the louver top with the very top edge of the 3/4" flange.
2. Line up the Wall Adapter holes with the threaded holes in the louver and securely tighten fasteners.

Final Wall Adapter and Architectural Louver Installation

NOTE: Ensure that the weather strip is undamaged and provides a continuous seal around the inner perimeter of the Wall Adapter.

Apply silicone grease or other non-petroleum-based lubricants to the weather strip to enhance the sealing capability of the weather strip and ease installation of the air conditioner chassis.

1. Loosen the two set screws located on the top side of the divider.
2. Slide the top part of the divider toward the outside until the sealing strip makes contact with the exterior louver.
3. Tighten the set screws to complete the adjustment.

NOTE: Let all flashing cure completely before installing the chassis.

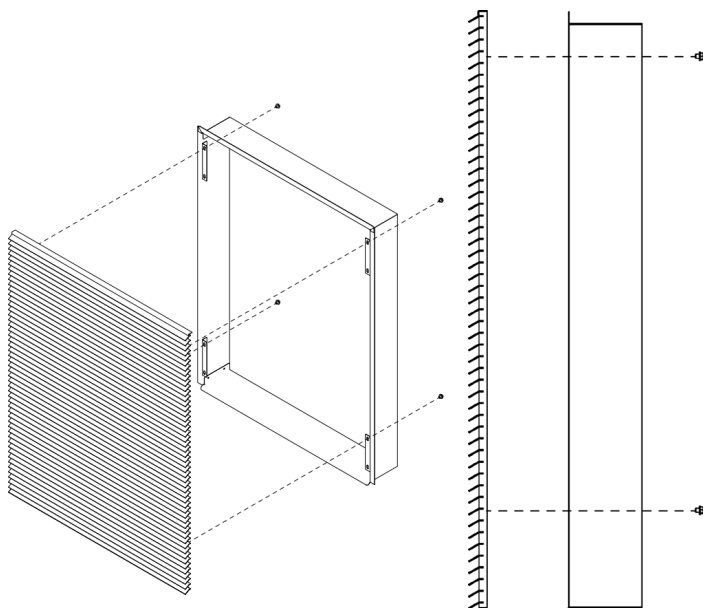

Installation of the louver AFTER the installation of Wall Adapter on elevated floors

From the interior of the utility closet:

1. Tie a rope or tether to the architectural louver and the divider in the Wall Adapter to prevent it from falling if dropped.
2. Turn the louver sideways and push the louver out below the divider in the Wall Adapter.
3. Pull the louver back against the Wall Adapter and align the holes.
4. Insert and tighten all eight provided fasteners. When the louver is secured, remove the safety tether.

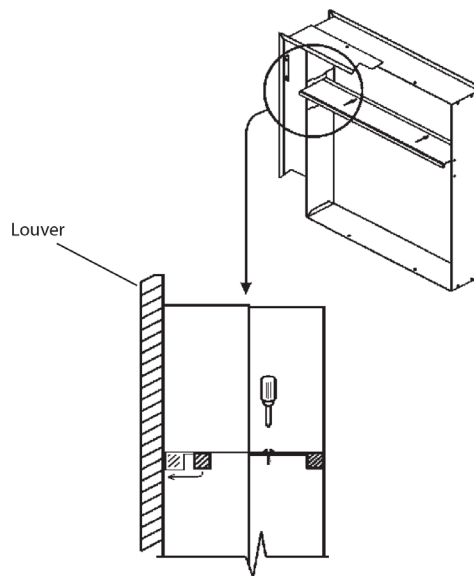
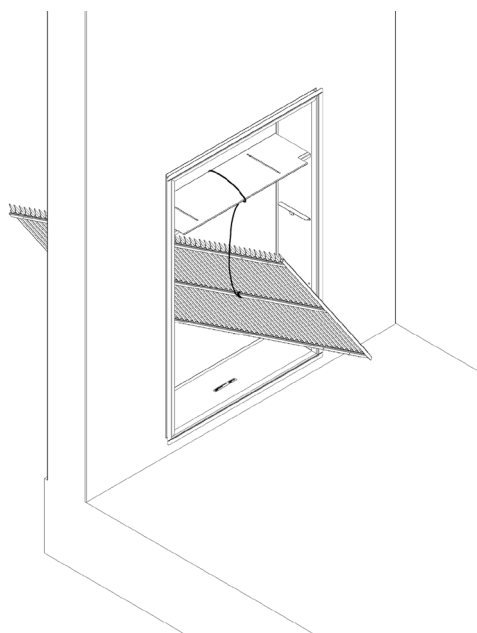

Primary Drain Connection and Location

For AVH09 & AVH12 Units only

NOTE: Failure to follow the following procedures may result in serious property damage. A field supplied secondary condensate pan or P-trap may be required. Check with local codes. In case of drainage system blockage, the unit base will allow excess water to flow out of the unit through the wall adapter and the architectural louver. It is critical to ensure that the drainage path is not blocked or obstructed in any way during the installation.

1. The supplied drain kit must be connected to one of the three (left, right or rear) 3/4" FPT connections on the unit base pan. Use of rear fitting without connection to DWV system (drain, waste, vent) may result in staining of the outside wall.
2. Insert the provided 3/4" nipple into the determined connection using field-supplied Teflon tape or pipe joint compound.
3. With the slip end of a 3/4" union, connect to the nipple with Teflon tape or pipe joint compound.
4. Hand-tighten all fittings to prevent damage to unit or fittings.
5. Install a field-supplied drain system to the slip end of the union. A trap is recommended and drain connections should be connected to building DWV system. Pitch the drain line of a 1/4" downward slope for every foot (1') of lateral horizontal run to the DWV.
6. Plug the two unused connection ports with the two provided 3/4" pipe plugs with field-supplied Teflon tape or pipe joint compound. Hand tighten to prevent damage to the unit or fittings. Do not thread metal or copper pipe fittings directly into unit.
7. Check the system for leaks.

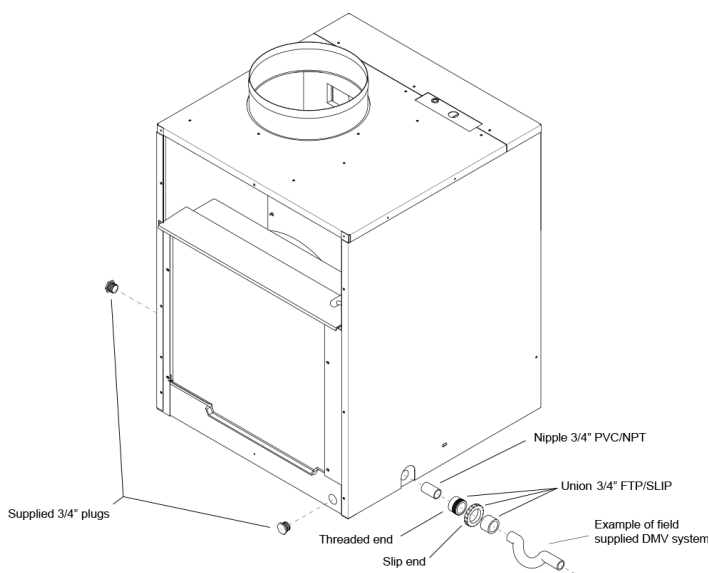

DRAIN PAN INSTALLATION

NOTE: This drain pan must be installed with all and AVH18-AVH24 "H" series units (Produced after September 2019).

Cut Opening in Gasket

Remove an 8 1/8" portion of the weather seal gasket from the bottom right surface of the plenum.

- Cut the gasket in the lower right corner of the plenum.
- Make a second cut 8 1/8" from the right corner. The gasket should peel away from the plenum leaving a clean mounting surface (See Figure 1).

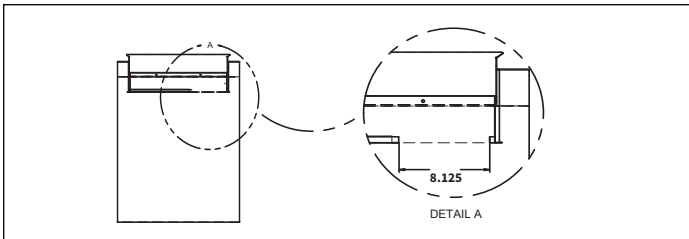

Figure 1

Seal and Set Pan

Prior to placing the drain pan into the opening run a 1/4" bead of sealant the entire width of the removed gasket. The secondary overflow lip must extend into the plenum to prevent water leaks. The pan should be mounted against the 3/4" flange of the plenum, refer to view A.

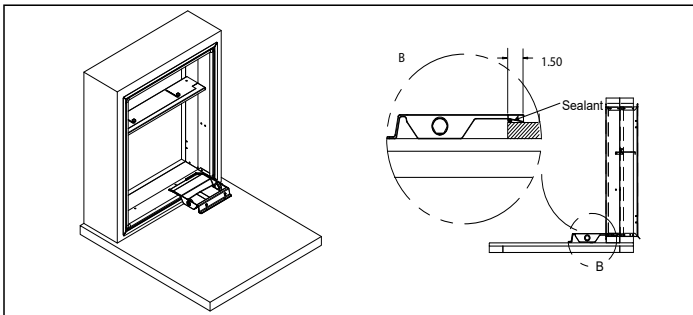

Figure 2

Install Drain Pan

Attach the drain pan to the closet floor with the appropriate field supplied hardware.

Important: To prevent water leaks use only the factory supplied mounting holes. NEVER make penetrations in the drain pan itself.

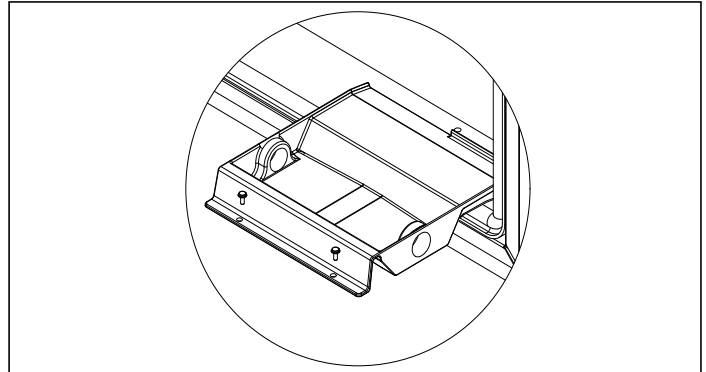

Figure 3

Install Drain Plug

The drain pan comes with both left and right-hand drain connections locations. Determine which of the two connections will be used to drain the condensate. Then, with the factory supplied drain plug, plug the unused opening.

Important: Proper sealant must be applied to the connection to prevent leaks.

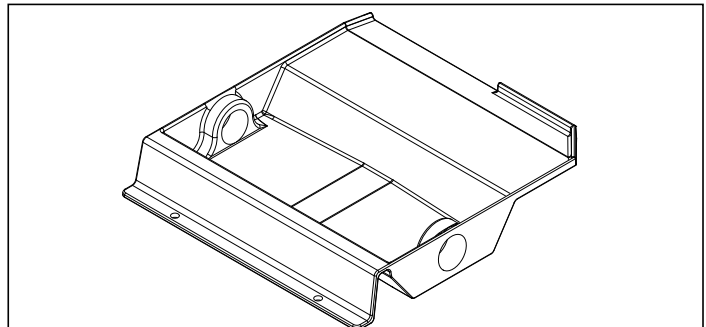

Figure 4

Install Drain Line

Condensate line routing options are shown below. Choose the one that best suits your installation.

Important: Never run the condensate line as shown in Option 4 below, as the drain line will come into contact with the factory-installed isolators beneath the unit.

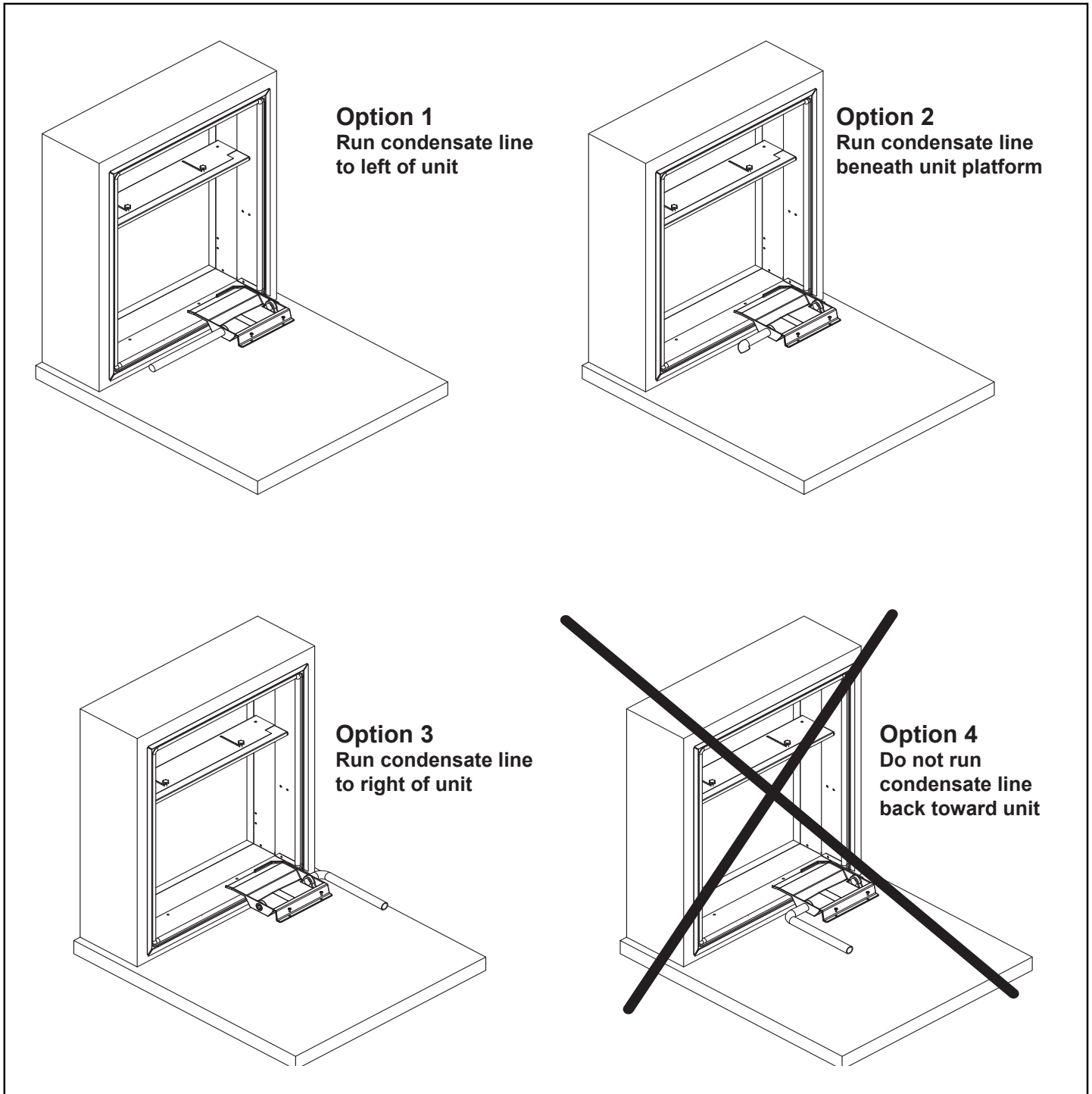

Figure 5

WIRING



WARNING

HIGH VOLTAGE

DISCONNECT ALL POWER BEFORE SERVICING OR INSTALLING THIS UNIT. MULTIPLE POWER SOURCES MAY BE PRESENT. FAILURE TO DO SO MAY CAUSE PROPERTY DAMAGE, PERSONAL INJURY OR DEATH. DO NOT SERVICE THIS UNIT WITHOUT FIRST SHUTTING OFF POWER TO THE UNIT FROM THE CIRCUIT BREAKER AND/OR REMOVING THE UNIT CORD SET PLUG FROM THE WALL OUTLET.



WARNING

DO NOT ALTER POWER CORD.
DO NOT REMOVE LDCI OR AFCI CIRCUIT BOARD.
DO NOT REPLACE TERMINALS OR OTHER PARTS OF THE CORD.
DO NOT USE CORD IF DAMAGED.
CONTACT SERVICE PARTS FOR A REPLACEMENT CORD, IF NEEDED.



WARNING

UNIT MAY **ONLY** BE HARD WIRED WITH A FACTORY SUPPLIED KIT.



CAUTION

TO AVOID PROPERTY DAMAGE, PERSONAL INJURY OR DEATH DUE TO ELECTRICAL SHOCK, DO NOT USE AN EXTENSION CORD WITH THIS UNIT.



CAUTION

TO AVOID RISK OF PROPERTY DAMAGE, PERSONAL INJURY OR FIRE, USE ONLY COPPER CONDUCTORS.



CAUTION

TO AVOID RISK OF PROPERTY DAMAGE, PERSONAL INJURY OR FIRE, DO NOT INSTALL WITH POWER CORD STRETCHED OR UNDER A STRAIN AS THIS MAY CREATE A LOOSE PLUG/RECEPTACLE CONNECTION.



CAUTION

TO AVOID THE RISK OF PERSONAL INJURY, WIRING TO THE UNIT MUST BE PROPERLY POLARIZED AND GROUNDED.



WARNING

THIS AIR CONDITIONER IS NOT MEANT TO PROVIDE UNATTENDED COOLING OR LIFE SUPPORT FOR PERSONS OR ANIMALS WHO ARE UNABLE TO REACT TO THE FAILURE OF THIS PRODUCT.
THE FAILURE OF AN UNATTENDED AIR CONDITIONER MAY RESULT IN EXTREME HEAT IN THE CONDITIONED SPACE CAUSING OVERHEATING OR DEATH OF PERSONS OR ANIMALS. PRECAUTIONS MUST BE TAKEN TO WARN OFF OR GUARD AGAINST SUCH AN OCCURRENCE.

Indoor Return Air Grille and Ductwork Installation

AVLWP01A-R & AVLWP01A-L Return Air Grille with Access Panel A field-supplied (25" x 20") filter can be mounted inside the hinged access door. The door can be installed with the grille oriented at the top of the panel for improved sound attenuation (Recommended for AVH09 & AVH12)



Option 1

Field Supplied Return Air Grille

A field supplied return air grille divorced from the access panel must have a minimum 250 square inches of free area.



Option 2



NOTE: All VTAC chassis are shipped with a filter installed (20" x 14" for AVH09, AVH12, & AVH18. 20" x 18" for AVH24). If a different filter holder or location is to be used, the filter on the chassis MUST be removed.

Ductwork

The supply duct system should be designed using a recognized method such as the equal fraction or velocity reduction method, using the appropriate duct calculator(s) for the type(s) of duct being used in the system. The duct system should be designed for a maximum friction rate of .3" water column taking into consideration all fittings, registers and/or diffusers.

NOTE: Do not operate the unit without a supply duct attached. The return air to the VTAC unit MUST NOT be ducted and all units must have a free return air configuration to perform properly.

Chassis Installation

 CAUTION	
<p>EXCESSIVE WEIGHT HAZARD USE TWO OR MORE PEOPLE WHEN INSTALLING YOUR AIR CONDITIONER. FAILURE TO DO SO CAN RESULT IN BACK OR OTHER INJURY.</p>	

 CAUTION	
<p>CUT / SEVER HAZARD SOME EDGES MAY BE SHARP, USE GLOVES OR OTHER HAND PROTECTION WHEN HANDLING UNIT. FAILURE TO DO SO CAN RESULT IN MINOR TO MODERATE PERSONAL INJURY.</p>	

1. Ensure that the wall adapter and louver are installed in accordance with the instructions listed on pages 5-7.
2. Place the chassis into the closet with the outdoor side facing the wall adapter opening.
3. Slide the chassis into the wall adapter until the adapter divider seal is established.

NOTE: The VTAC chassis must be inserted into the wall adapter so that the adapter divider gasket makes contact with the plastic condenser baffle on the unit. The chassis will fit approximately 2 3/8" into the wall adapter.

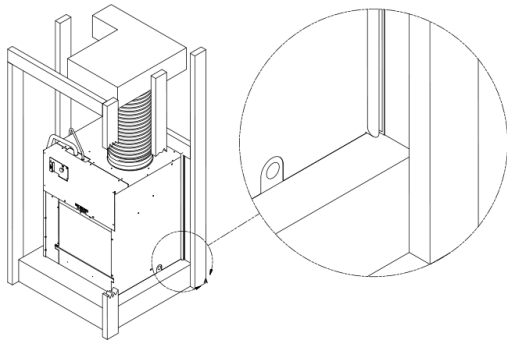

Remote Thermostat and Low Voltage Control Connection

Remote Thermostat

All VTAC units are factory configured to be controlled by using a single stage heat/cool remote wall mounted thermostat. The thermostat may be auto or manual changeover as long as the control configuration matches that of the VTAC unit.

To connect the wall mounted thermostat:

1. Pull the disconnect switch.
2. Unscrew and remove the control box panel.
3. Select which side to run your thermostat wire.
4. Run the wires through the side hole in the box to reach the connection terminal wiring.
5. Make the connections, appropriately matching the wires as shown in the wiring diagram.
6. Reattach the control box cover.

Front Desk Control Terminals

The VTAC has built-in provisions for connection to an external switch to control power to the unit. The switch can be a central desk control system door switch.

For desk control operation, connect on side of the switch to the D1 terminal and the other to the D2 terminal. When the circuit is closed, unit operation will stop.

NOTE: The desk control system and switches must be field supplied.

Maximum Wire Length for Desk Control Switch

AWG Wire Size	Maximum Length (ft.)
24	400
22	600
20	900
18	1500
16	2000

Auxiliary Fan Control

The VTAC also has the ability to control a 24VAC relay to activate an auxiliary or transfer fan. The outputs are F1 and F2 on the control board.

To connect the relay, simply wire one side of the relay to F1 and the other side to F2.



NOTE: The relay and auxiliary fans must be field supplied. The relay must be 24VAC @ 100mA or less.

Interface Definition

Terminal Code	Wire Connection Function
C	Common Ground Terminal
GH	Call for High Fan
GL	Call for Low Fan
B	Call for Heat Pump (Reversing Valve)
Y	Call for Compressor
W	Call for Heating (Electric)
R	24VAC to Wall Thermostat

NOTE: It is the installer's responsibility to ensure that all control wiring connections are made in accordance with the installation instructions. Improper connection of the thermostat control wiring and/or tampering with the unit's internal wiring can void the equipment warranty and may result in property damage, personal injury, or death. Questions concerning proper connections to the unit should be directed to the factory.

Final Installation Checklist

 WARNING	
HIGH VOLTAGE DISCONNECT ALL POWER BEFORE SERVICING OR INSTALLING THIS UNIT. MULTIPLE POWER SOURCES MAY BE PRESENT. FAILURE TO DO SO MAY CAUSE PROPERTY DAMAGE, PERSONAL INJURY OR DEATH.	

- Inspect and ensure that all components and accessories have been installed properly and that they have not been damaged during the installation process.
- Ensure that all installation instructions concerning clearances around the unit have been adhered to.
- Check to ensure that the unit air filter, indoor coil, and outdoor coil are free from any obstructions.
- Ensure that the circuit breaker(s) or fuse(s) and supply circuit wire size have been sized correctly.
- Check the condensate water drain(s) to ensure that they are adequate for the removal of condensate water and that they meet approval of the end user.
- Ensure that the entire installation is in compliance with all applicable national and local codes and ordinances having jurisdiction.
- **ENSURE THAT THE SUPPLY VOLTAGE TO THE UNIT IS WITHIN THE OPERATING RANGE**
- Secure all access panels (i.e. front cover and/or control box), apply power to the unit. The unit commissioning should be done at this time to ensure unit function.

NOTE: Maintaining a log for recording the dates of maintenance and/or service is recommended, and should be suggested to the owner or operator of the equipment.

- Present the owner or operator of the equipment with the Installation & Operation Manual, all accessory installation instructions, and the name, address and telephone number Warranty Service Company in the area for future reference if necessary.

NOTE: The unit is not designed to guarantee continuous operation with outdoor ambient conditions greater than 110°F.

Chassis Operation

Fresh Air Door

The fresh air door is an “intake” system. It is opened via a slide mechanism on the front of the chassis located just above the indoor coil. Move the slide left to open and right to close the door. The system is capable of delivering up to 60 CFM of outdoor air.

Low Ambient Compressor Cut Out

Each chassis is equipped with low ambient protection that is determined by thermistor feedback. The feedback will prevent the compressor from operating at low suction temperatures.



Room Freeze Protection

This feature will monitor the indoor room conditions and in the event that the room falls below 40°F, the unit will cycle on high fan with the electric heater. This occurs regardless of mode.

Chassis Final Connections

With the chassis in place, you are now ready to begin chassis connections:



- A. Move the thermostat switches to “OFF” and “AUTO”. This will keep the thermostat from cycling the chassis until final connections are complete.
- B. Connect the duct work onto the 10” collar. Plastic wire ties (field supplied) are suggested to secure the duct work in place. Use 2 wire ties, one for each inner and outer flex duct sleeve.
- C. Review the Final Installation Checklist before replacing the power quick disconnect, reconnecting power to the chassis, or operating the chassis.

 WARNING	
HIGH VOLTAGE DISCONNECT ALL POWER BEFORE SERVICING OR INSTALLING THIS UNIT. MULTIPLE POWER SOURCES MAY BE PRESENT. FAILURE TO DO SO MAY CAUSE PROPERTY DAMAGE, PERSONAL INJURY OR DEATH.	

Service & Warranty

Servicing / Chassis Quick Changeouts

The chassis is designed for quick disconnect and change out. For minor electrical service, the control box cover lifts straight up after the screws & disconnect head are removed. For major electrical, refrigeration and fan service the chassis may be removed from utility closet.

 WARNING
<p>HIGH VOLTAGE DISCONNECT ALL POWER BEFORE SERVICING OR INSTALLING THIS UNIT. MULTIPLE POWER SOURCES MAY BE PRESENT. FAILURE TO DO SO MAY CAUSE PROPERTY DAMAGE, PERSONAL INJURY OR DEATH.</p> 

Routine Maintenance

Performing Routine Maintenance

With the proper maintenance and care, your system will operate economically and dependably. Maintenance can be accomplished easily by referring to the following directions. However, before performing any maintenance, see above stated **WARNING**.

 CAUTION
<p>CUT / SEVER HAZARD SOME EDGES MAY BE SHARP, USE GLOVES OR OTHER HAND PROTECTION WHEN HANDLING UNIT. FAILURE TO DO SO CAN RESULT IN MINOR TO MODERATE PERSONAL INJURY.</p> 

Replace Air Filter

A dirty air filter reduces the efficiency of the VTAC and allows lint and dirt to accumulate on the indoor-air coil. Lint and dirt on the indoor-air coil can damage your unit. The air filter should be replaced as it becomes dirty.

To replace the filter (chassis mounted return air filter):

1. Slide the filter clear of the filter rails.
2. Remove the filter.
3. Install new disposable filter.

NOTE: DO NOT OPERATE YOUR SYSTEM WITHOUT A FILTER IN PLACE OR BLOCK THE FRONT OF THE UNIT RETURN AIR OPENING.

To Remove the Chassis from the Closet:

- A. Switch the wall thermostat off.
- B. Pull the Power Disconnect located in the front of the chassis.
- C. Disconnect the power coming into the unit from the main breaker panel or the closet mounted disconnect.
- D. Disconnect the electrical connection.
- E. Disconnect the duct work.
- F. Slide the chassis out of the wall adapter.
- G. Lift the chassis out of the utility closet.

Inspect and Clean Indoor-air Coil

Eventually, minor amounts of lint and dirt may pass through the filter and collect on the indoor-air. These minor accumulations can be carefully vacuumed away with a brush attachment on a vacuum cleaner. Care must be taken to avoid bending the aluminum fins on the coil. Bent fins should be straightened using a special fin tool available from most HVAC supply depots.

Inspect Outdoor-Air (OA) Intake and Exhaust

The unit's outdoor-air intake and outdoor-air exhaust paths must remain clear. Check the OA exhaust frequently. Keep it free of all debris, snow, or ice. The OA intake should also be kept free of obstructions. Blocking the OA exhaust or OA intake opening will reduce the efficiency of your unit and could damage it.

Inspect and Clean Condensate Drain

The condensate drain must be routed to a suitable drainage area. Check the unit condensate drain periodically. Keep it free of anything that may block or impede the flow of condensate water. If there is any accumulation of foreign matter in the drain pipe, it should be removed and cleaned. The entire drain line must be protected from freezing.

Warranty

All warranty service work must be done by an authorized servicer. See Product Warranty, and consult your dealer or contractor for details.

Electronic Control Error Code Diagnostics and Test Mode

Error Code Diagnostics

The VTAC electronic control continuously monitors the VTAC unit operation and will store error codes if certain conditions are witnessed. In some cases the unit may take action and shut the unit off until conditions are corrected.

To access the error code menu press the **'ENTER'** button. If error codes are present they will be displayed. If multiple codes exist you can toggle between error codes using the **'SCROLL'** button. To clear all codes press the **'ENTER'** and **'SCROLL'** buttons for three seconds while in the error code mode. To exit without losing codes press the **"LOW FAN"** button.

ERROR CODES AND ALARM STATUS

Unit Control Panel

The display shown below has four (4) digits. The left two digits indicate the error code (1 to 24), The On/Off icons above these two digits indicate the current state of the error code. The right two digits show the history count (up to 99) of the associated error code. The display contains a maintenance icon (wrench) that will illuminate to indicate when the unit needs maintenance.

Error Code	Problem	Action
1	Front Panel Button Stuck For More Than 20 Seconds	Continue to Monitor for "OPEN" (Unstuck) switch. Do not process switch input.
2	Input Voltage Out of Specification (103-127/187-253)	Unit stops, open all relays until voltage is back within specs then resume operation.
3	Indoor Temperature Sensor is Open or Shorted	Unit defaults to 75°F in COOLING or 68°F in HEATING and will continue to operate.
4	Indoor Coil Temperature Sensor is Open or Shorted	The unit's control board defaults 40°F. It will override the sensor and the unit will continue to operate.
5	Outdoor Coil Temperature Sensor is Open or Shorted	The unit defaults to 20°F, overriding the sensor. The unit will continue to operate. Using Elec Heat if available for HEATING. If not available, it will use HEAT PUMP if the outdoor temperature allows.
6	Outdoor Coil > (greater than) 175°F	The unit will shut down for 5 minutes. Resume operation for 3 minutes. If test fails 3 times, the severity is increased and the unit operation is locked out.
7	Indoor Coil < (less than) 30°F for 2 consecutive minutes	The compressor will turn off and the High Fan speed will run. When coil temp reaches 45°F the unit will resume operation after lockout time.
8	Unit Cycles > (greater than) 9 Times per hour	The unit will continue to operate and be monitored.
9	Unit Cycles < (less than) 3 Times per Hour	The unit will continue to operate and be monitored.
10	Room Freeze Protection	Only use if Electric Heat is available. Run High Speed and Electric Heat until room temp reaches 46°F. The unit will display "FRZ" during operation. Logged Only.
11	WallStat Problem or Connection Issue	The unit will not operate.
12	Not Applicable	Not Applicable
13	High Pressure Limit Switch is Open	If unit is cooling or heat pump is on, shut down compressor. Run high fan until switch closes, then resume operation. The third occurrence in 1 hour locks unit out. Applicable to 24K unit only.
14	Not Applicable	Not Applicable
15	Heat Pump Error	If indoor coil temperature is less than ambient temperature for 3 minutes the unit will use electric heat to satisfy the heating demand.
16	Temperature Beyond Operating Limits	Occurs if the ambient temperature range falls below 0°F or greater than 130°F. The error code will remain on until the temperature reaches the operating range and then the unit will return to normal operation.
17	Equipment Doesn't Meet Minimum Configuration	The compressor must be enabled and have at least 2 fan speeds
18	Not Applicable	Not Applicable
19	Not Applicable	Not Applicable
20	Not Applicable	Not Applicable
21	Not Applicable	Not Applicable
22	Outdoor Coil Temperature < 30°F for 2 consecutive Minutes	Unit will use electric heat to satisfy heating demands until the temperature equals or exceeds 45°F. Applicable for Heat Pump models only.
23	Frost Protection	Unit will run active defrost for a minimum of 6 minutes when Heat Pump run time is greater than 60 minutes and outdoor coil temperature is 26°F or less.
24	Not Applicable	Not Applicable

Obtaining Service

In the event this unit requires repair or servicing beyond what is covered in this manual, contact an authorized service organization.

To obtain an authorized servicer, contact your sales representative.

CUSTOMER FEEDBACK

Daikin is very interested in all product comments.

Please fill out the feedback form on the following link:

<https://daikincomfort.com/contact-us>

You can also scan the QR code on the right to be directed to the feedback page.



Amana is a registered trademark of Maytag Corporation or its related companies and is used under license to Goodman Company, L.P., Houston, TX, USA. All rights reserved.

5151 San Felipe, Suite 500 • Houston, TX 77056 • www.amana-ptac.com
© 2014 - 2015, 2017 - 2018 Goodman Company, L.P.