

NEW PRODUCT

Product Specifications

NATIONAL SLEEP FOUNDATION

The **Bedroom Machine**

by **austin**

Portable Room Air Cleaner



STAGE 1 - Large Particle Pre-filter

- Removes particles easily seen by the naked eye (e.g. dust, hair and pet dander)

STAGE 2 - Medium Particle Pre-filter

- Removes small to medium size particles (e.g. molds, spores and pollen)

STAGE 3 - 15 lbs. of Proprietary Carbon Blend

- Removes chemicals, gases and odors (e.g. sulfuric acid and ammonia)

STAGE 4 - 60 sq. ft. of Certified HEPA

- Removes 99.97% of all particles larger than 0.3 microns

STAGE 5 - HEGA Carbon Cloth

- High Efficiency Gas Arrestance

FAN/MOTOR ASSEMBLY

- Centrifugal fan
- 3-speed control switch
- PSC motor
- Power - 1.1 amp
- 135 watts at highest setting
- CSA, NRTL and CE approved

HOUSING CONSTRUCTION

- 22 gauge steel
- Powder coating paint finish
- 360 degree intake

DIRECTIONAL AIR FLOW

Austin Air's directional air flow allows you to direct air into breathing area where you stand, sit or sleep.

DIMENSIONS

- Height: 23 inches
- Width: 14.5 x 14.5 inches
- Weight: 45 pounds

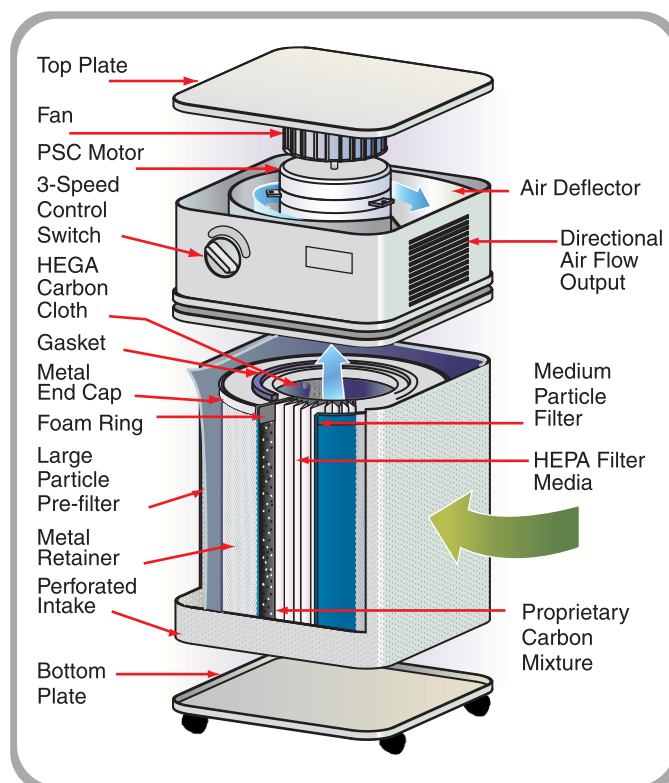
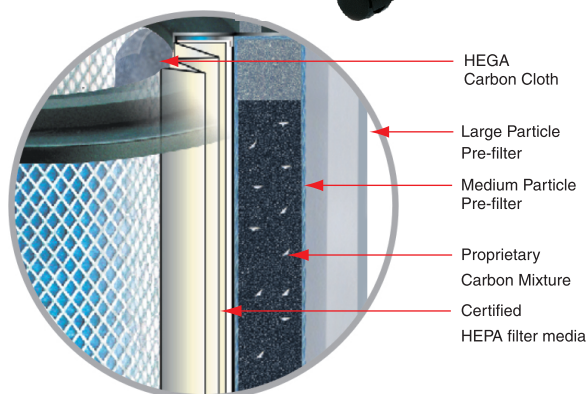

WARRANTY

Five years on all parts and labor excluding the filter cartridge. The filter cartridge comes with a 5 year pro-rated guarantee.

