

SAFETY INSTRUCTIONS

WARNING

1. Improper installation may cause property damage or injury. Installation, service, and maintenance must be performed by a qualified service technician.
2. 120 Volts may cause serious injury from electric shock. Disconnect electrical power before starting installation or servicing. Leave power disconnected until installation/service is completed.
3. Sharp edges may cause serious injury from cuts. Use care when cutting plenum openings and handling ductwork.
4. Dropping may cause personal injury or equipment damage. Use tools or two people to transport dehumidifier.

CAUTION

1. Read all instructions before beginning installation.
2. Do not use in pool applications. Pool chemicals can damage the dehumidifier.
3. Do not use solvents or cleaners on or near the circuit board. Chemicals can damage circuit board components.
4. Wait 24 hours before running if the unit has not been shipped or stored in the upright position.

TABLE OF CONTENTS

Safety Instructions	1	Installation Configurations	
Overview	2	Whole-Home Installation	6
Specifications	3	Spot Installation	8
Unpacking and Contents	3	Convertible Installation	10
Location Considerations	4	Ventilation or Air Cycling	12
Mechanical Installation		Model 70 Living Space Control	16
Duct Collars & Backflow Damper	5	Third-Party Control	17
Ductwork Recommendations	5	System Checkout	18
Drain.	6	Troubleshooting	19
Float Switch	6		

READ AND SAVE THESE INSTRUCTIONS

OVERVIEW

The Aprilaire® Dehumidifier is designed to control humidity inside the whole home. The dehumidifier uses a dew point calculation to control the humidity based on the dryness set point on the dehumidifier control. An optional Model 70 Living Space Control or third-party control can be used in place of the onboard control.

The dehumidifier has a built in feature to allow air cycling or ventilation. Air cycling allows activation of the HVAC fan to cycle air throughout the home for airflow balance and comfort. Ventilation brings fresh air into the home and is designed to meet ASHRAE 62.2 Standard for Ventilation.

There are three main installation options, Whole-Home, Spot, and Convertible.

WHOLE-HOME, see page 6

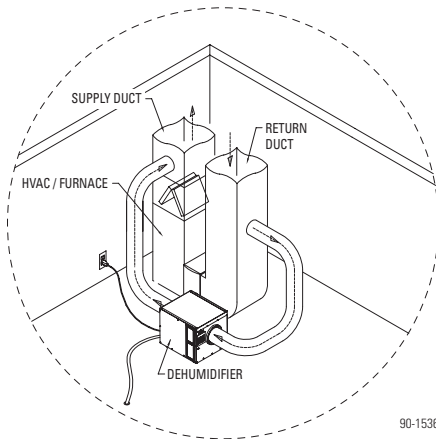

In a Whole-Home installation, the dehumidifier works in conjunction with the HVAC system, offering the optimum solution for year-round, whole-home control. This installation is typically in basement or attic locations. In a typical setup, air is pulled from the return duct, dehumidified, and returned to the supply duct. Alternate duct configurations are possible.

SPOT, see page 8

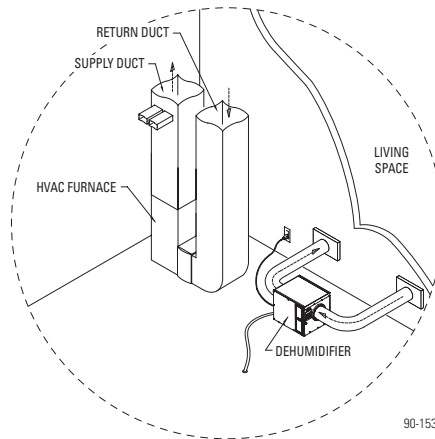

In a Spot installation, the dehumidifier is not ducted to the HVAC system and is used to dehumidify a specific area. This installation is typically in basements or crawl spaces, with the dehumidifier ducted to the area requiring dehumidification. Grilles on the inlet and outlet are added to increase the pressure drop across the unit.

CONVERTIBLE, see page 10

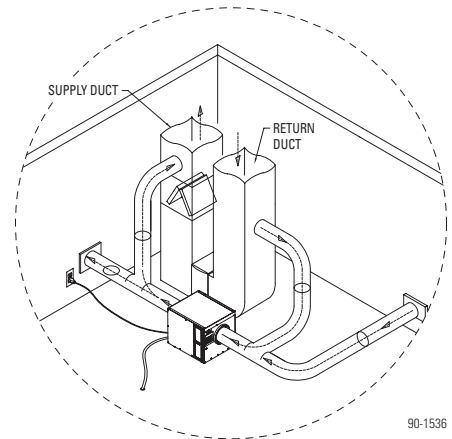

In a Convertible installation, the dehumidifier controls humidity in both whole-home and spot locations. The dehumidifier will dehumidify the whole home as the first priority, switching to the spot location after the whole-home dehumidification need has been met.

SPECIFICATIONS

Dimensions: 20-3/4"W x 24"L x 20-5/8"H
Adjustable feet allow for 22-5/8" total height

Weight: 1750A – 93 lbs.
1770A – 100 lbs.

Capacity: 1750A – 90 pints per day @ 275 CFM
1770A – 135 pints per day @ 500 CFM
AHAM DH-1-2003 80°F, 60%RH conditions

Power: 1750A – 115 VAC, 8 A, 15 A circuit
1770A – 115 VAC, 14 A, 20 A circuit
Unit equipped with 8 ft. grounded power cord

Operating Conditions:
Compressor: 50°F–100°F, 40°F dew point minimum
Ambient/Inlet Air: 40°F–140°F, 0%–95% RH (non-condensing)

Filter: MERV 8, washable

Compressor Minimum Off Time: 3 minutes
Compressor Minimum On Time: 3 minutes

Airflow:

1750A	
External Static Pressure	Airflow
0.0 "w.c.	385 CFM
0.4 "w.c.	340 CFM
0.6 "w.c.	275 CFM

1770A	
External Static Pressure	Airflow
0.0 "w.c.	535 CFM
0.7 "w.c.	515 CFM
0.9 "w.c.	500 CFM

UNPACKING AND CONTENTS

Do not tip unit to remove from carton.

1. Open carton completely by cutting each corner from top to bottom.
2. Remove all cardboard inner pack.
3. See **Figure 1** for opening view and contents.
 - a. Installation Instructions
 - b. Owner's Manual
 - c. Duct Collars, 2
 - d. Drain Trap
 - e. 90° PVC Elbow
 - f. Backflow Damper

FIGURE 1 – Opening View and Contents

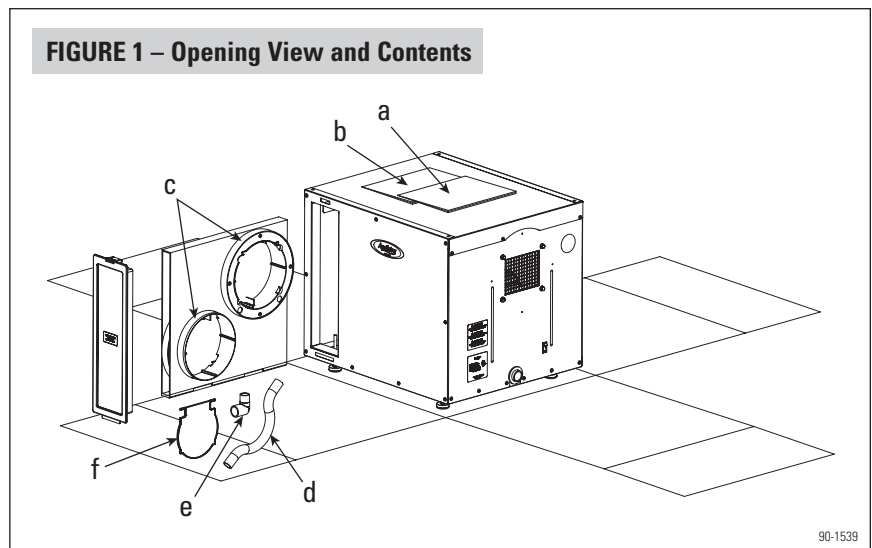

90-1539

LOCATION CONSIDERATIONS

- 1. Install Unit Indoors:** Do not expose to elements.
- 2. Drain Accessibility:** A condensate pump may be required if a drain is not located in the installation area.
- 3. Power:** Outlet within 8 ft. of unit.
- 4. Filter Access:** Allow for 20" of clearance on one side of unit for removal of filter (see **Figure 2**).
- 5. Inlet:** Allow for 12" of clearance to access control and control door/wiring access (see **Figure 2**).

TABLE 1 – Location Notes

Requirement	Application Location			
	Attic	Garage	Basement	Crawl Space
All ductwork must be insulated and sealed.	✓	✓		✓
Drain pan with overflow protection placed under unit.	✓			

FIGURE 2 – Dimensions and Location Considerations

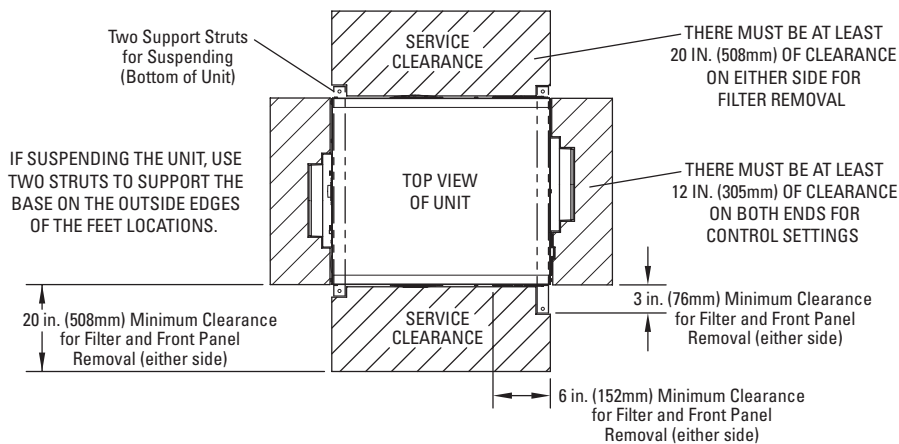
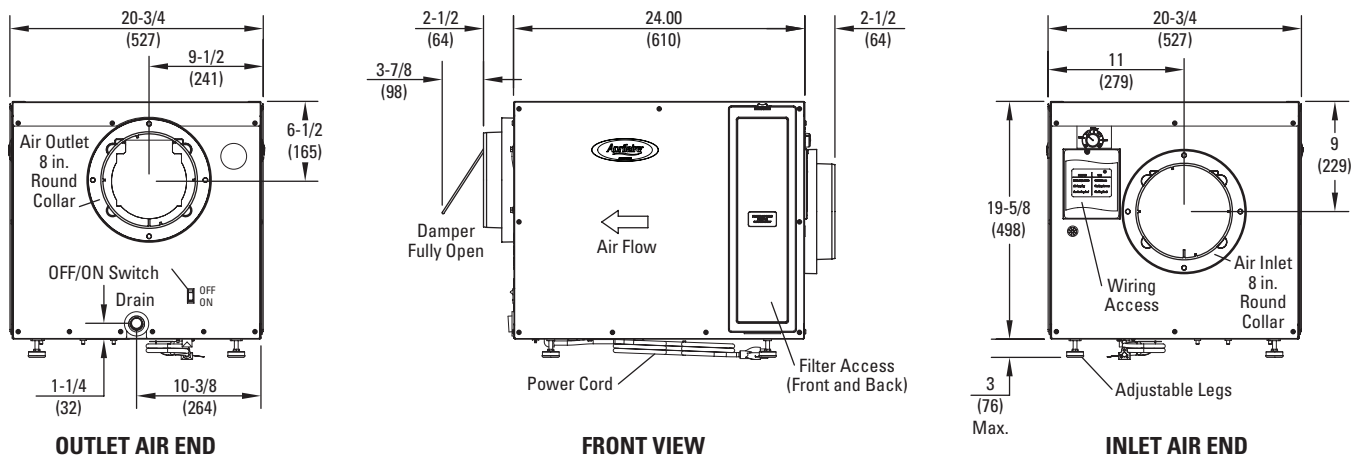

MECHANICAL INSTALLATION

DUCT COLLARS & BACKFLOW DAMPER

The backflow damper installs on the outlet side of the dehumidifier, using features molded into the duct collar.

1. Remove the duct collars and backflow damper from the inner pack.
2. Place the backflow damper in the collar with the damper pivot shaft resting in the slot in the collar (see **Figure 3**).
3. Position the collar and damper with damper pivot shaft up and install on the outlet panel using four #8 x 1" field supplied sheet metal screws (see **Figure 4**). The collar should sit flush on the outlet panel and secure the backflow damper.
4. Verify that the damper swings freely by lifting up on the damper and allowing it to swing closed.
5. Make sure there are no bends in the ductwork coming off the outlet for a minimum of 4". This will ensure that the ductwork will not interfere with backflow damper function (see **Figure 5**).

FIGURE 3 – Install Damper in Collar

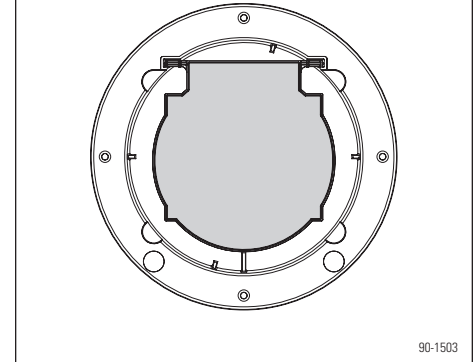

90-1503

FIGURE 4 – Install Collar with Damper on Outlet

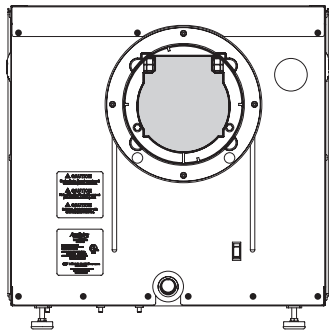

CAUTION

Only install damper on outlet. Dehumidifier will not function if damper is installed on inlet.

90-1503

FIGURE 5 – Minimum Ductwork Bend Distance

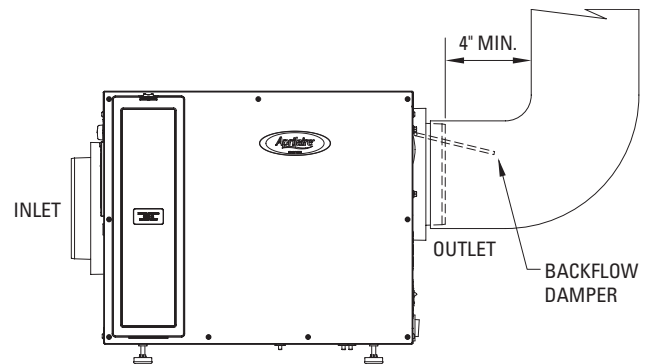

90-1503

DUCTWORK RECOMMENDATIONS

TABLE 2 – Design Airflows

	1750A	1770A
CFM	275	500
External Static Pressure	0.6" w.c.	0.9" w.c.
Amount of 8" Ducting	70 ft.	100 ft.

Notes:

1. Duct length totals include both inlet and outlet sides.
2. Elbows, turns, and the static pressure of the HVAC equipment will affect the airflow through the dehumidifier.
3. **Static Pressure Maximums:** 1750A – 0.8" w.c.
1770A – 1.5" w.c.
4. Ductwork to be installed in accordance with SMACNA Standards.

- When ducted to the HVAC supply, the outlet from the dehumidifier must be located at least 6" downstream of the cooling coil to prevent outlet air from pulling moisture from the coil.
- To minimize sound from air movement and vibration, install 5 feet minimum of flex duct on the inlet and outlet of the dehumidifier.
- Use the least amount of ductwork possible. UL approved, insulated duct is recommended for all connections.
- If ventilating, use insulated duct on the dehumidifier inlet duct.

MECHANICAL INSTALLATION (CONTINUED)

DRAIN

1. Adjust feet of dehumidifier to allow a 2-1/2" minimum clearance for drain trap. See **Figure 6**. Use the 90° elbow if necessary for clearance restrictions. See **Figure 7**.
2. Use PVC primer and cement for drain assembly to the dehumidifier drain outlet.
3. Complete assembly by piping the 3/4" PVC trap to a drain or condensate pump. Make sure the drain line has a constant downward slope and is not kinked.
4. To prime the drain trap and to verify the drain line is not blocked, slowly pour a pint of water into the dehumidifier drip pan located below the coil.

CAUTION

1. Drain trap must be primed with water before use.
2. A condensate pan with a float switch is required in attic installations.

FIGURE 6 – Drain Trap

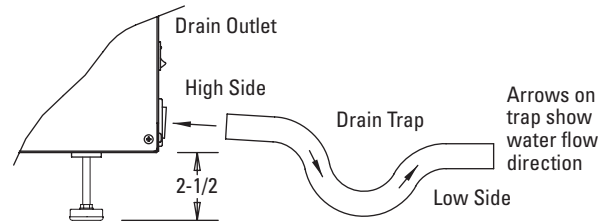
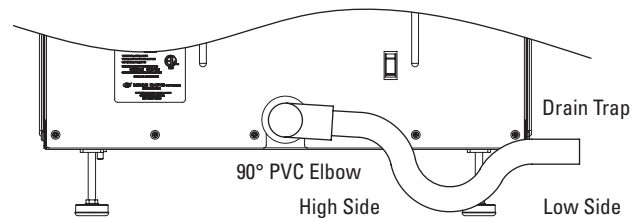

FIGURE 7 – Drain Trap with 90° Elbow



FLOAT SWITCH

If the dehumidifier is installed in an attic or another location requiring leak protection, the unit should be placed in a condensate pan with a normally closed, condensate overflow safety switch (float switch). Remove the jumper from the float switch terminals on the control board and wire the float switch to the terminals. See **Figure 8**.

FIGURE 8 – Float Switch Wiring

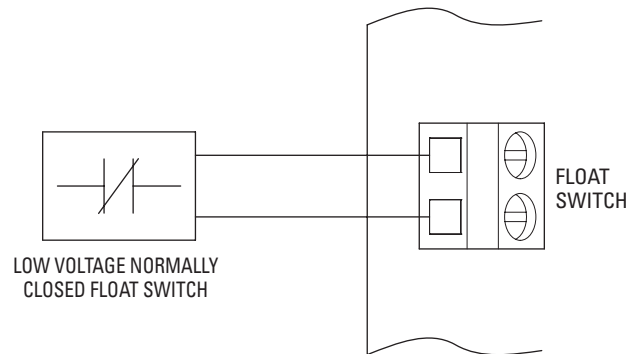

WHOLE-HOME INSTALLATION

This installation is used when the HVAC equipment conditions the whole home. Using the dehumidifier in conjunction with the HVAC system is the optimum solution for year-round, whole-home control. This installation is typically in basement or attic locations. Ducting the unit to the return and supply, where air is pulled from the return duct, dehumidified, and discharged to the supply duct, is the most common setup. Additional configurations include only ducting the dehumidifier outlet to the supply or ducting the inlet and outlet to the return duct. In the latter case, the HVAC fan must be activated during dehumidification.

Required Components

Duct Work
18 – 22 AWG Wire

Optional Components

Condensate Pan & Normally Closed Float Switch
Model 70 Living Space Control
Third-Party Control

WHOLE-HOME INSTALLATION (CONTINUED)

BASEMENT DUCTING & WIRING

FIGURE 9 – Whole-Home Basement Installation

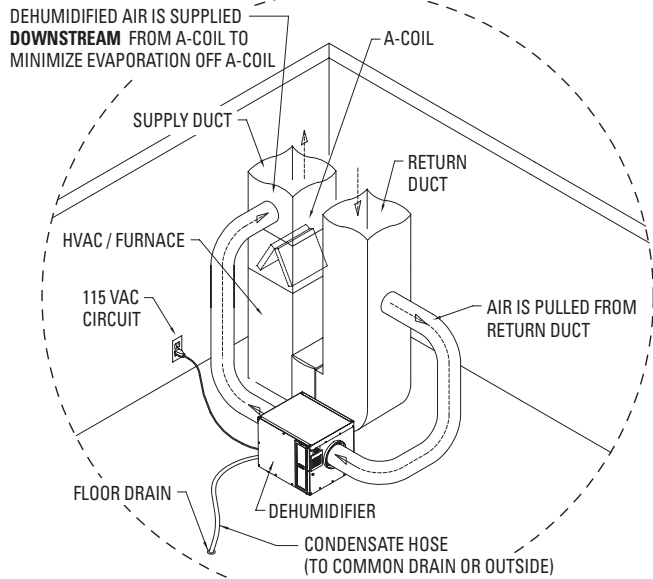

90-1536

FIGURE 10 – Whole-Home Basement Wiring

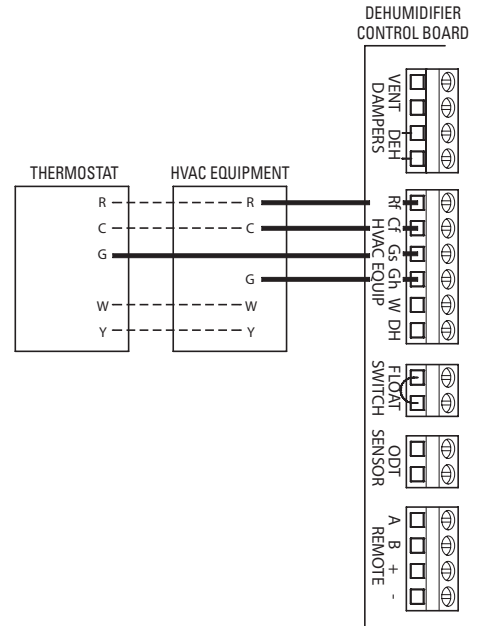

90-1537

ATTIC DUCTING & WIRING

FIGURE 11 – Whole-Home Attic Installation

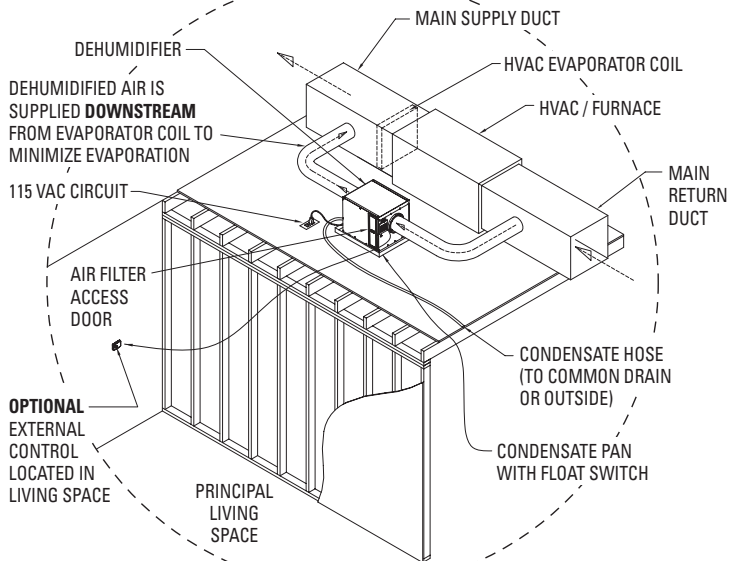

90-1536

FIGURE 12 – Whole-Home Attic Wiring

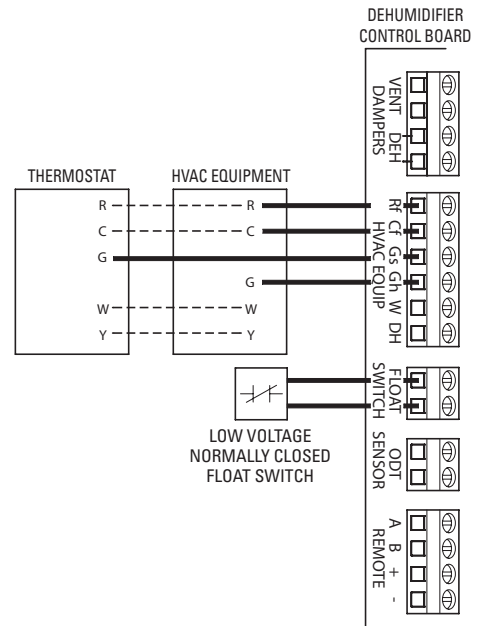

90-1537

Attic Installation Note:

The dehumidifier must be installed in a secondary condensate pan with a float switch.

Wiring Notes:

- If wiring to a Model 70 Living Space Control, see MODEL 70 LIVING SPACE CONTROL section on page 16.
- If wiring to a third-party control, see THIRD-PARTY CONTROL section on page 17.

WHOLE-HOME INSTALLATION (CONTINUED)

DIP SWITCH CONFIGURATION

- **HVAC FAN ON:** Activating the HVAC fan during dehumidification is recommended because it offers better circulation and balancing of indoor air conditions. Running the HVAC fan during dehumidification does not affect moisture removal efficiency. If the switch is put in the HVAC FAN OFF position, air is pulled through the unit, dehumidified, and circulated solely by the dehumidifier blower.
- **CYCLE PERIOD:** This determines how frequently the dehumidifier will sample the air to check the humidity level. Set to 1 hour and adjust as needed.
- For Ventilation switch settings, see VENTILATION section beginning on page 12.
- For Local/External switch setting, see THIRD-PARTY CONTROL on page 17.

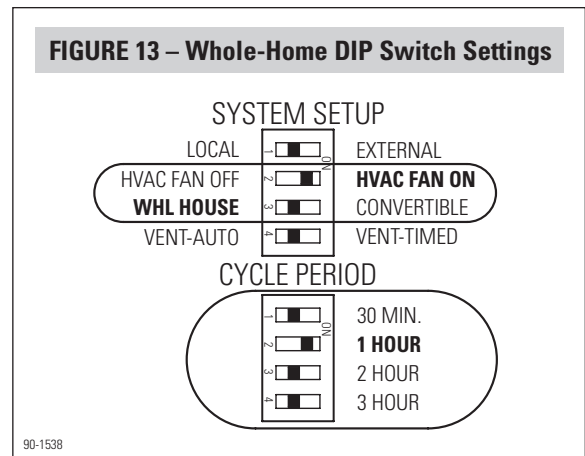

SEQUENCE OF OPERATION

- Sampling will occur once within the Cycle Period. Sampling is initiated with the first HVAC fan (Gs) call or at the end of the Cycle Period if a HVAC fan call is not received within the Cycle Period. At the onset of sampling, the dehumidifier damper output turns on, the dehumidifier blower turns on, and the green Status LED flashes.
- After three minutes, the dew point of the incoming air is measured and compared to the set point on the control knob. If the dew point of the incoming air is above the set point, the compressor turns on and the green Status LED switches to solid illumination. If the dew point is below the set point, the dehumidifier damper output turns off and the dehumidifier blower turns off along with the green Status LED.
- The dew point of the incoming air is continuously monitored during compressor operation. When the dew point of the incoming air falls below the set point on the control knob, the dehumidifier damper output turns off and the dehumidifier compressor and blower turn off along with the green Status LED.

SPOT INSTALLATION

In this installation the dehumidifier is not ducted to the HVAC system and is used to dehumidify a specific area. This installation is typically used in basements or crawl spaces. The dehumidifier can remain non-ducted, however, to achieve specified performance it is recommended that the dehumidifier be ducted to the area requiring dehumidification. When ducted, grilles should be installed on the inlet and outlet to increase the pressure drop across the unit. 10 feet is the recommended distance between inlet and outlet grilles.

Required Components

Duct Work
Grilles with 8" duct collars

Optional Components

Condensate Pan & Normally Closed Float Switch
Model 70 Living Space Control
Third-Party Control

SPOT INSTALLATION (CONTINUED)

DUCTING & WIRING

FIGURE 14 – Spot Ducted Installation

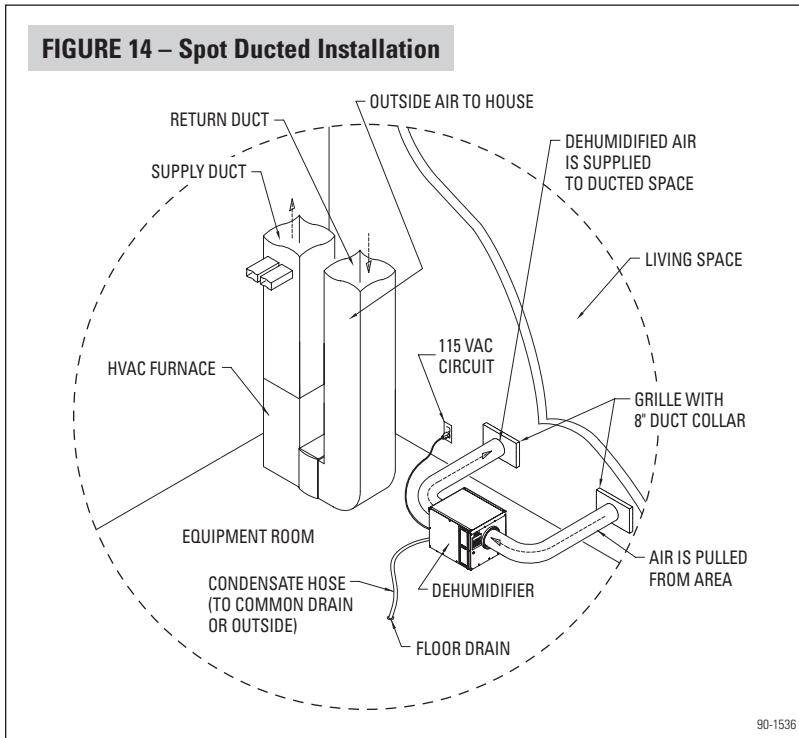

Wiring Notes:

- No additional wiring required.
- If wiring to a Model 70 Living Space Control, see MODEL 70 LIVING SPACE CONTROL section on page 16.
- If wiring to a third-party control, see THIRD-PARTY CONTROL section on page 17.

DIP SWITCH CONFIGURATION

- **CYCLE PERIOD:** This determines how frequently the dehumidifier will sample the air to check the humidity level. Set to 1 hour and adjust as needed.
- For Ventilation switch settings, see VENTILATION section beginning on page 12.
- For Local/External switch setting, see THIRD-PARTY CONTROL on page 17.

FIGURE 15 – Spot DIP Switch Settings

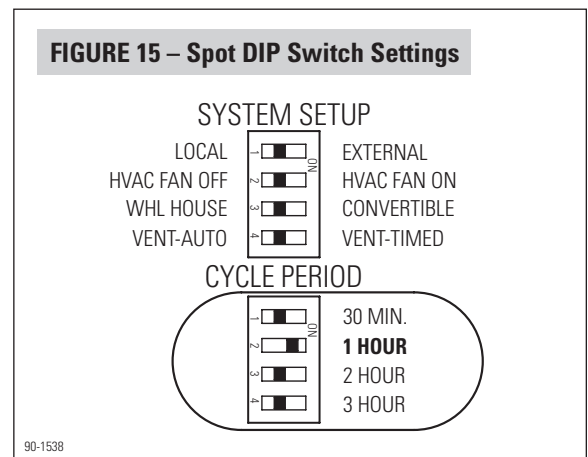

SEQUENCE OF OPERATION

- Sampling will occur at the end of the Cycle Period. At the onset of sampling, the dehumidifier damper output turns on, the dehumidifier blower turns on, and the green Status LED flashes.
- After three minutes, the dew point of the incoming air is measured and compared to the set point on the control knob. If the dew point of the incoming air is above the set point, the compressor turns on and the green Status LED switches to solid illumination. If the dew point is below the set point, the dehumidifier damper output turns off and the dehumidifier blower turns off along with the green Status LED. The next sampling will occur at the end of the next Cycle Period.
- The dew point of the incoming air is continuously monitored during compressor operation. When the dew point of the incoming air falls below the set point on the control knob, the dehumidifier damper output turns off and the dehumidifier compressor and blower turn off along with the green Status LED.

CONVERTIBLE INSTALLATION

In this installation the dehumidifier controls humidity in both the whole-home and a spot location. The dehumidifier will dehumidify the whole home as the first priority, switching to the spot location after the whole-home dehumidification need has been met. Ducting the unit to the return and supply, where air is pulled from the return duct, dehumidified, and discharged to the supply duct, is the most common setup, with additional ducting run to and from the spot location(s).

Note: Convertible Mode will not work with ventilation, air cycling, or continuous HVAC fan operation. The Model 70 Living Space Control and third-party controls (see pages 16-17) cannot be used in Convertible Mode operation.

Required Components

- Duct Work
- 18 – 22 AWG Wire
- Grilles with 8" Duct Collars
- 2 – Aprilaire Model 6508, 8" Normally Closed Damper
- 2 – Aprilaire Model 6608, 8" Normally Open Damper
- 24 VAC Transformer (40VA min.) for Dampers

NOTE: 4522 Basement Kit includes 2 – 6508 Dampers, 2 – 6608 Dampers and a 24 VAC Transformer.

Optional Component

- Condensate Pan & Normally Closed Float Switch

DUCTING & WIRING

FIGURE 16 – Convertible Installation

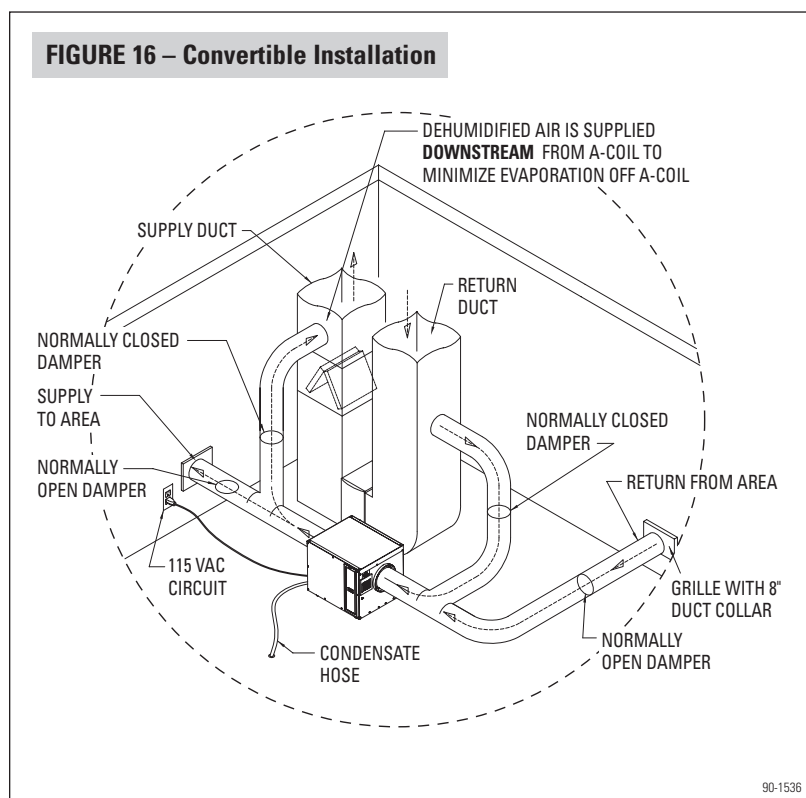
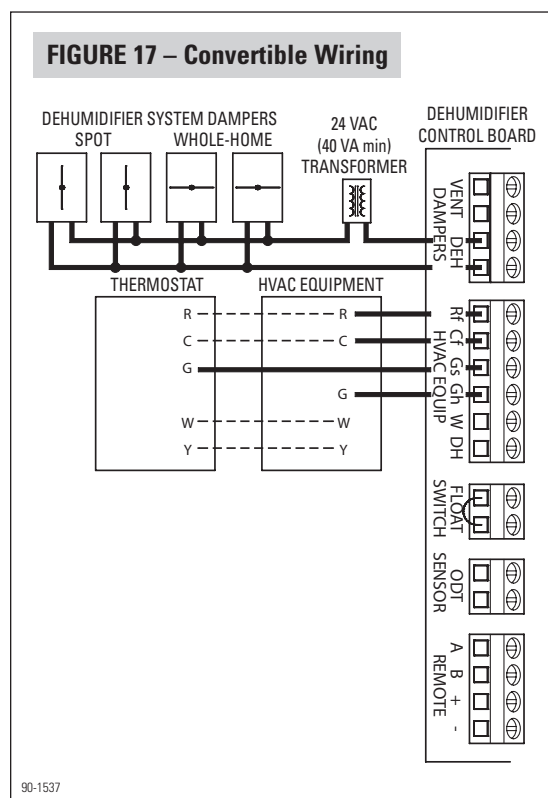

FIGURE 17 – Convertible Wiring



CONVERTIBLE INSTALLATION (CONTINUED)

DIP SWITCH CONFIGURATION

- **HVAC FAN ON:** Activating the HVAC fan during Whole-Home dehumidification is recommended because it offers better circulation and balancing of indoor air conditions. Running the HVAC fan during dehumidification does not affect moisture removal efficiency. During spot dehumidification, the HVAC fan will not be turned on regardless of the position of the switch. If the switch is put in the HVAC FAN OFF position, air is pulled through the unit, dehumidified, and circulated solely by the dehumidifier blower.
- **CYCLE PERIOD:** This determines how frequently the dehumidifier will sample the air to check the humidity level. Set to 1 hour and adjust as needed.
- **CYCLE TIME:** The cycle time potentiometer must be set to OFF for proper operation.

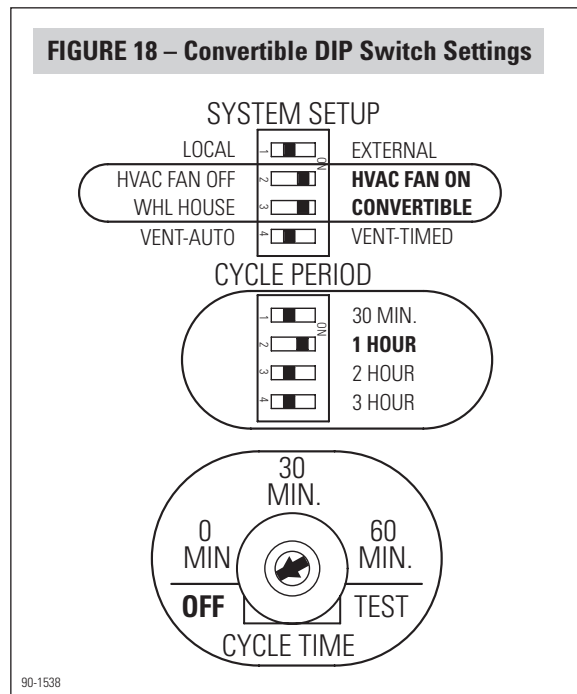

SEQUENCE OF OPERATION

- Whole-Home sampling will occur with the first HVAC fan (Gs) call within the Cycle Period and will override Spot dehumidification.
- At the onset of Whole-Home sampling, the dehumidifier damper output turns on, the dehumidifier blower turns on, and the green Status LED flashes. After three minutes, the dew point of the incoming air is measured and compared to the set point on the control knob. If the dew point of the incoming air is above the set point, the compressor turns on and the green Status LED switches to solid illumination. If the dew point is below the set point, the dehumidifier damper output turns off and the dehumidifier blower turns off along with the green Status LED.
- If a Whole-Home sampling does not occur, Spot sampling will occur at the end of the Cycle Period, if not actively dehumidifying the whole-home. At the onset of spot sampling, the dehumidifier blower turns on and the green Status LED flashes. After three minutes the dew point of the incoming air is measured and compared to the set point on the control knob. If the dew point of the incoming air is above the set point, the compressor turns on and the green Status LED switches to solid illumination. If the dew point is below the set point, the dehumidifier blower turns off along with the green Status LED.
- The dew point of the incoming air is continuously monitored during compressor operation. When the dew point of the incoming air falls below the set point on the control knob, the dehumidifier damper output turns off and the dehumidifier compressor and blower turn off along with the green Status LED.
- After the dehumidifier blower has turned off, one minute must elapse before it can be turned on again (i.e., following a Whole-Home sampling). If one minute has not elapsed, the Status LED will flash and the dehumidifier blower will turn on after one minute.

VENTILATION OR AIR CYCLING

The dehumidifier has outputs available to open a normally closed damper and introduce outdoor air through an outdoor air intake duct. Ventilation is controlled by the Cycle Period switches, Cycle Time potentiometer, and Vent-Auto/Vent-Timed switches. If a normally closed ventilation damper is not installed, the dehumidifier will function in Air Cycling mode, activating the HVAC blower to cycle air through the home based on the Cycle Period and Cycle Time.

Required Components

Aprilaire Model 6506, 6" Normally Closed Damper
24 VAC Transformer (10VA min.) for Ventilation Damper

Optional Component

8052 Outdoor Temperature Sensor

DUCTING & WIRING

FIGURE 19 – Whole-Home with Ventilation

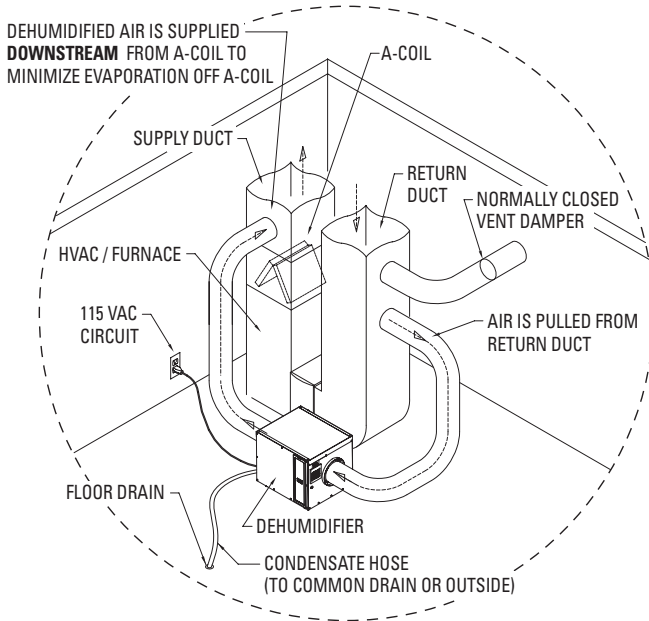

Ducting Note: Direct ducting the ventilation intake duct to the dehumidifier inlet duct is acceptable if the incoming temperature of the mixed air will be greater than 40°F and less than 100°F.

90-1536

FIGURE 20 – Ventilation Wiring

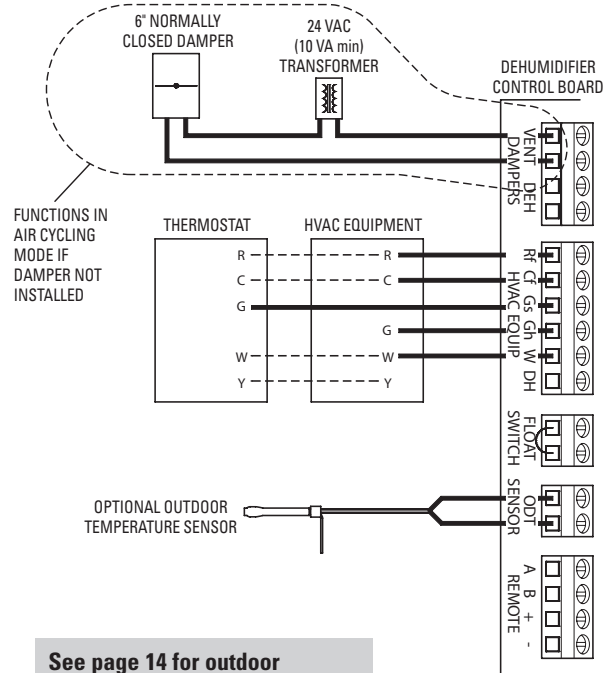

See page 14 for outdoor temperature sensor installation.

90-1537

DETERMINE VENTILATION REQUIREMENTS

CALCULATING AIRFLOW REQUIREMENT

- The MINIMUM ventilation requirement is calculated using ASHRAE 62.2-2007.

$$\text{ASHRAE Airflow in CFM} = [\text{House Area in Sq. Ft.} \times 0.01] + [(\text{Number of Bedrooms} + 1) \times 7.5]$$

Notes: Use 'Number of Bedrooms +1' or the 'Number of Occupants', whichever is larger.

- Table 3** shows calculated airflow values to the nearest 5 CFM. If more outdoor air is required, a second device is advised.
- Record the Required CFM. _____

TABLE 3 – CFM Required

House Sq. Ft.	Number of Bedrooms				
	2	3	4	5	6
1000	35	40	50		
1500	40	45	55	60	70
2000	45	50	60	65	75
2500	50	55	65	70	80
3000	55	60	70	75	85
3500			75	80	90

VENTILATION OR AIR CYCLING (CONTINUED)

DETERMINE FRESH AIR DELIVERY RATE

1. Measure the negative static pressure of the return system at the location where the outdoor air duct enters the return duct.
2. See **Table 4** for estimated inlet airflow in CFM, based on duct type, length, and available negative pressure. Use an airflow measuring device for a more accurate airflow delivery rate.
3. Record the Delivered CFM. _____

TABLE 4 – CFM Delivered												
Duct Length	Negative Static Pressure ("w.c.) as Measured for Return Duct or Plenum											
	0.05		0.1		0.15		0.2		0.25		0.3	
	Flex	Pipe	Flex	Pipe	Flex	Pipe	Flex	Pipe	Flex	Pipe	Flex	Pipe
10 ft.	60	65	85	90	105	110	120	125	135	140	150	160
20 ft.	55	60	80	85	100	105	115	120	130	135	140	150
30 ft.	50	55	75	80	95	100	110	115	125	130	130	140

Note: For the table above, 6" flex duct is laid loose with two, wide 90° bends and a fully opened damper. Rigid pipe values are based on 6" duct, two 90° elbows, and a fully open damper. In both cases, the air intake is through a metal vent hood with inlet screen. Airflow may need to be adjusted up or down for variations in duct work.

DETERMINE CYCLE TIME

1. Use the Required CFM and Delivered CFM from the above steps to determine the Cycle Time from **Table 5**.
2. The values are listed for a 1 hour Cycle Period. For a 2 hour Cycle Period, set the Cycle Time to twice the values listed in **Table 5**.
3. The values highlighted in gray cannot be set due to the maximum 60 minute Cycle Time. A second ventilation device (i.e., bigger duct or second duct) will be required to meet ventilation needs.

TABLE 5 – Cycle Time Setting (minutes) for Airflow Delivered vs. Airflow Required for 1 hour Cycle									
CFM Delivered	CFM Required								
	20	30	40	50	60	70	80	90	100
60	20	30	40	50	60	70	80	90	100
80	15	25	30	40	45	55	60	70	75
100	15	20	25	30	35	40	50	55	60
120	10	15	20	25	30	35	40	45	50
140	10	15	15	20	25	30	35	40	45
160	10	10	15	20	25	25	30	35	40

VENTILATION OR AIR CYCLING (CONTINUED)

SETTING DIP SWITCHES & CYCLE TIME TO MEET VENTILATION REQUIREMENTS

FIGURE 21 – VENT-TIMED DIP Switch Settings

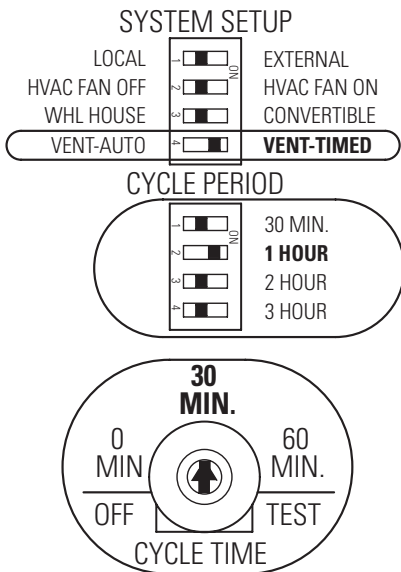

90-1538

FIGURE 22 – VENT-AUTO DIP Switch Settings

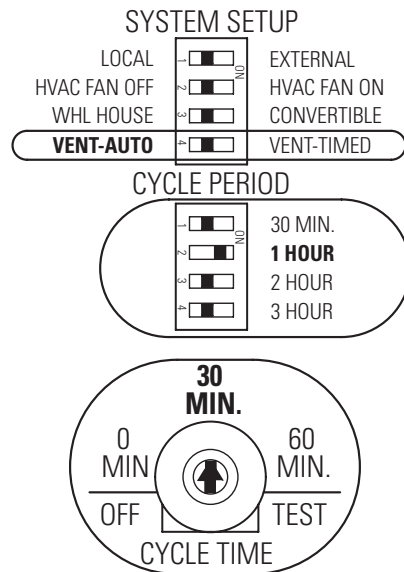

90-1538

Switch Notes:

- Setting the Cycle Time \geq Cycle Period will result in constant ventilation.
 - Setting the Cycle Time to OFF will disable ventilation.
1. Set VENT-AUTO and VENT-TIMED switch. VENT-AUTO restricts ventilation based on outdoor temperature (incoming air conditions) and VENT-TIMED allows ventilation regardless of outdoor air conditions. The VENT-AUTO configuration requires the installation of the Model 8052 outdoor temperature sensor (ODT).
 2. Set the Cycle Period by moving the 1/2, 1, 2, or 3 hour switch to the ON position. The Cycle Period is the time over which a ventilation cycle will occur. The default position is 1 hour.
 3. Set the Cycle Time, determined in **Table 5**, by rotating the potentiometer between 0 minutes and 60 minutes. The Cycle Time determines how long during each Cycle Period ventilation will occur. Once the ventilation time requirement is met, ventilation will not occur until the next cycle period.

OUTDOOR TEMPERATURE SENSOR INSTALLATION

The ODT should be installed outside in a shaded location (see **Figure 23**), or in the outside intake ventilation duct (see **Figure 24**).

FIGURE 23 – ODT Mounted Outside

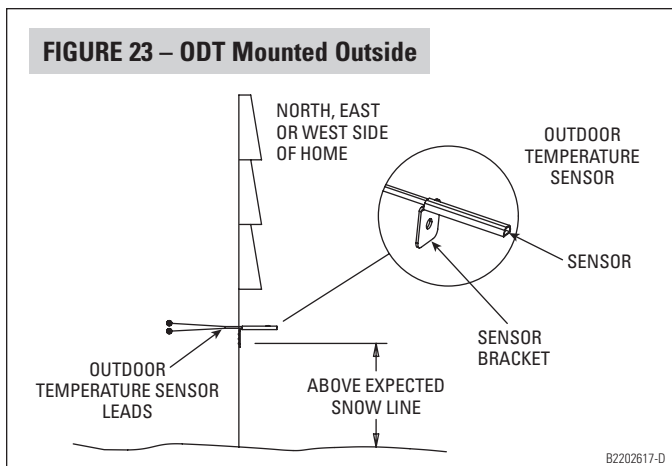

B2202617-D

FIGURE 24 – ODT Mounted in Intake Duct

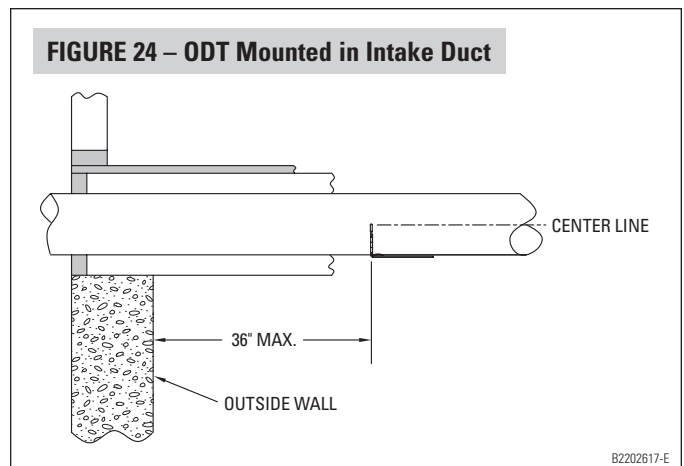

B2202617-E

VENTILATION OR AIR CYCLING (CONTINUED)

SEQUENCE OF OPERATION

VENT-TIMED, HVAC INITIATES VENTILATION

- Ventilation will occur whenever there is an HVAC fan (Gs) or heat (W) call and will continue until the ventilation time has met the set Cycle Time during the set Cycle Period. During ventilation the dehumidifier damper output turns on, the ventilation damper opens, the dehumidifier blower turns on, and the Status LED flashes.
- When the HVAC heat or fan call has ended or when the ventilation time requirement has been met, the dehumidifier damper output turns off, the ventilation damper closes, and the dehumidifier blower turns off along with the green Status LED.
- Two minutes must elapse following the end of a HVAC fan or heat call before the dehumidifier can initiate a ventilation cycle.

VENT-TIMED, DEHUMIDIFIER INITIATES VENTILATION

- When the amount of time remaining in the Cycle Period is equal to the amount of Cycle Time required, the HVAC fan turns on, the dehumidifier damper output turns on, the ventilation damper opens, the dehumidifier blower turns on, and the Status LED flashes.
- When the ventilation time requirement has been met, the HVAC fan turns off, the dehumidifier damper output turns off, the ventilation damper closes, and the dehumidifier blower turns off along with the green Status LED.
- To prevent short cycling the fan, a ventilation cycle will not start unless there are at least 2 minutes remaining in the Cycle Period.

DEHUMIDIFICATION DURING VENTILATION

When not controlled by the Model 70 Living Space Control or third-party control, the dehumidifier will continually measure the conditions of the incoming air during ventilation.

- The dew point of the air is measured 3 minutes after the dehumidifier blower is turned on and every 15 seconds while the blower is running.
- If the dew point of the air is above the setting on the control knob, the compressor turns on and the green Status LED switches to solid illumination.
- When the dew point of the air falls below the control knob set point, the compressor turns off and the Status LED flashes.

VENT-AUTO

Ventilation in the Vent-Auto configuration is functionally the same as Vent-Timed operation, with the exception of the temperature limits applied to the incoming air.

- If the incoming air temperature is greater than or equal to 100°F, the ventilation damper closes. If the temperature drops to 95°F or lower during the same ventilation cycle, the ventilation damper will open.
- If the incoming air temperature is less than or equal to 0°F, the ventilation damper closes. If the temperature increases to 5°F or higher during the same ventilation cycle **and** the ventilation cycle was initiated by a HVAC heat (W) call, the ventilation damper will open.
- If the air temperature is less than or equal to 20°F and above 0°F, the ventilation damper will close unless a HVAC heat (W) call is initiated during the ventilation cycle. If the air temperature drops to 0°F or below during the same ventilation cycle, the ventilation damper closes. If the temperature rises to 25°F or higher during the same ventilation cycle, the ventilation damper will open.

MODEL 70 LIVING SPACE CONTROL

The Model 70 Living Space Control contains its own sensors that override the main control sensors on the dehumidifier. The purpose of utilizing the Model 70 is to have the dehumidifier control located in a living area, where the homeowner can monitor and control humidity levels. Once connected and powered, the Model 70 is automatically recognized by the dehumidifier and will continuously communicate the air conditions and the dew point setting to the dehumidifier control. No sampling is needed when using a Model 70 because the control is located in the space to be conditioned and is measuring the dew point in that space. Refer to the Model 70 Installation Instructions for location and mounting instructions. The Convertible configuration is not available with the Model 70 Living Space Control.

WIRING & DIP SWITCH CONFIGURATION

FIGURE 25 – Model 70 Wiring

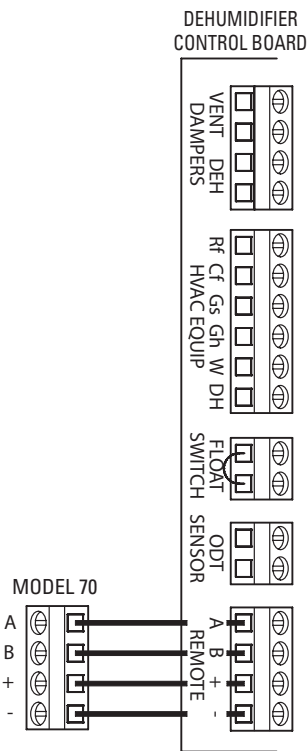

90-1537

FIGURE 26 – Model 70 DIP Switch Configuration

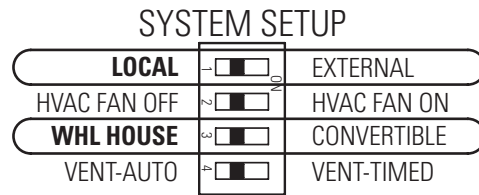

90-1538

SEQUENCE OF OPERATION

Whole-Home

- There is a 6 minute delay upon power up or after cycling power.
- If the dew point of the air is above the dew point setting on the Model 70, the dehumidifier damper output turns on, the dehumidifier blower turns on, and the green Status LED flashes.
- Three seconds after the dehumidifier blower turns on, the compressor turns on, and the green Status LED switches to solid illumination.
- When the dew point falls below the dew point setting on the Model 70, the dehumidifier damper output turns off and the dehumidifier compressor and blower turn off along with the green Status LED.

THIRD-PARTY CONTROL

An external thermostat with dehumidifier connections can be used as an ON/OFF dehumidifier control. In this configuration, the third-party control initiates dehumidification and overrides the on-board dehumidifier control logic. The dehumidifier control knob can only be used to initiate Test Mode when a third-party control is used. The Convertible configuration is not available with a third-party control.

WIRING & DIP SWITCH CONFIGURATION

FIGURE 27 – Third-Party Control Wiring

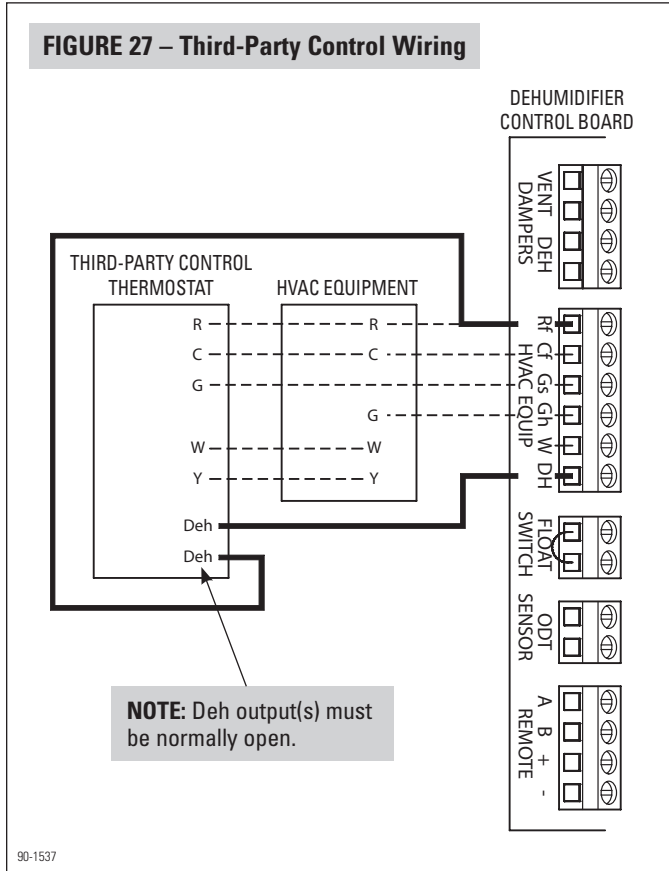
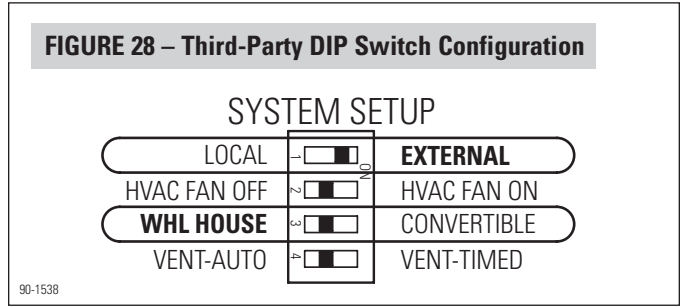

FIGURE 28 – Third-Party DIP Switch Configuration



Wiring Notes:

The dehumidifier Rf and Cf terminals must be powered from the transformer that powers the third-party control.

Third-Party Control with 2 Dehumidifier Connections

1. Connect one thermostat dehumidifier terminal to the Rf terminal on the dehumidifier control board.
2. Connect the other thermostat dehumidifier terminal to the DH terminal on the dehumidifier control board.

Third-Party Control with 1 Dehumidifier Connection

Connect the thermostat dehumidifier terminal to the DH terminal on the dehumidifier control board.

SEQUENCE OF OPERATION

- When the third-party control makes a dehumidification call, the dehumidifier damper output turns on, the dehumidifier blower turns on, and the green Status LED flashes.
- After 3 seconds the compressor turns on and the green Status LED switches to solid illumination.
- When the third-party control ends a dehumidification call, the dehumidifier damper output turns off and the dehumidifier blower and compressor turn off along with the green Status LED.

SYSTEM CHECKOUT

DEHUMIDIFICATION

1. Check the wiring to the HVAC equipment and any accessories if applicable.
2. Plug unit in and turn on/off switch to ON.
3. Rotate the main control knob clockwise to the TEST position.
4. If set up correctly, the dehumidifier blower will turn on and the dehumidifier damper output will turn on. After 30 seconds the dehumidifier compressor will turn on. The blower and compressor will remain on for 1 minute in TEST mode. After 1 minute has elapsed, the dehumidifier blower and compressor will turn off and the dehumidifier damper output will turn off. **NOTE:** If the minimum off time for the compressor has not expired when the test mode is initiated, the compressor will not turn on until the minimum off time has been met. If the blower or compressor fails to turn on, refer to the Troubleshooting Guide.
5. The Status LED will blink red and green alternately if the control knob has been left in TEST after the compressor has turned off.

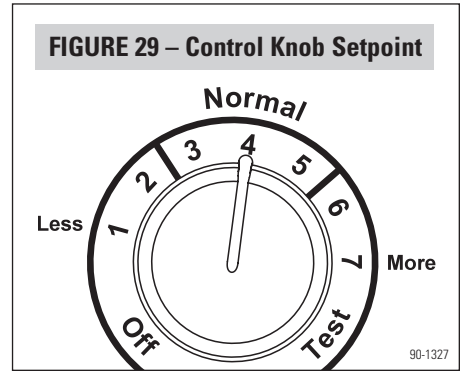

ADJUSTING DEHUMIDIFIER SET POINT

1. Use the control knob on the unit to set the desired dryness level.
 - Based on indoor temperature, use **Table 6** to determine the control knob setting to achieve the desired humidity level.
 - For most installations, start with a setting in the NORMAL range. See **Figure 29**.
 - Moving the knob clockwise towards MORE will increase dehumidifier run time, allowing for lower humidity levels.
 - Moving the knob counterclockwise towards LESS will decrease dehumidifier run time, allowing for higher humidity levels.
2. Reference Model 70 Living Space Control or Third-Party Control's Installation Instructions for start-up with a separate control.

Note: There is a 6 minute delay after power up when using a Model 70.

TABLE 6 – %RH (± 5%) Based on Control Knob Setting & Indoor Temperature

Control Knob Setting & Dew Point	Indoor Temperature			
	65°F	70°F	75°F	80°F
1 – Less, 65°F DP		84%	71%	60%
2 – 60°F DP	86%	73%	61%	52%
3 – Normal, 56°F DP	74%	63%	53%	45%
4 – Normal, 52°F DP	64%	54%	45%	39%
5 – Normal, 48°F DP	55%	46%	39%	33%
6 – 44°F DP	47%	39%	33%	28%
7 – More, 40°F DP	40%	34%	28%	24%

EXAMPLE: At an indoor temperature of **75°F** and a control knob setting of **3 (56°F DP)**, the dehumidifier will work to achieve a **53%** humidity level.

- The %RH values are ± 5% and are to be used as a **GUIDE ONLY** for initial set-up.
- Indoor temperature is measured at the inlet to the dehumidifier.

VENTILATION

1. Verify 24 VAC is applied in series with the normally-closed damper and connected to the VENT DAMPER terminals on the dehumidifier control board.
2. Remove the control door and rotate the CYCLE TIME potentiometer clockwise to the TEST position. See **Figure 30**.
3. If set up properly, the HVAC blower will turn on and the ventilation damper will open. The HVAC blower will remain on and the ventilation damper will remain open for 1 minute or until the dial is turned from the TEST position. **DO NOT leave CYCLE TIME set to TEST.** If the HVAC blower fails to turn on or the damper fails to open, refer to the Troubleshooting Guide.

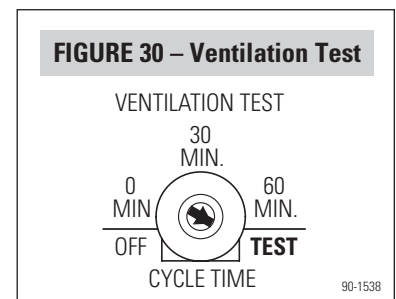

TROUBLESHOOTING

Technical Support is available Monday through Friday, 7:00 a.m. to 5:00 p.m. CST, at (800) 334-6011. Use the guides on the following pages to help find and correct system faults. Contact Technical Support before replacing the unit or components or for additional troubleshooting.

LED CODES

The dehumidifier control board uses the Status LED to communicate current status or a fault code. Faults can be either critical or non-critical. When a critical fault is detected, the red LED will flash the fault code and all outputs will immediately turn off. A critical fault can be cleared by repairing the fault **and** cycling power or turning the control knob to OFF. When a non-critical fault is detected, the red LED will flash the fault code and the dehumidifier will revert to limited operation. A non-critical fault will be cleared when the fault is repaired. Cycling power is not required to revert back to full operation.

TABLE 7 – Green LED Codes

Activity	Status
Solid ON	Compressor ON
Blinking 1 sec. ON & 1 sec. OFF	Sampling
Blinking 1/2 sec. ON & 1/2 sec. OFF	Defrosting
Alternating Green & Red	Test Mode

TABLE 8 – Red LED Codes

Number of Blinks	Fault Type	Failure Mode	Failure Condition	Action
1	Critical	Internal RH sensor fault.	RH sensor non-existent, erratic or reads out of 0% – 100% range.	<ol style="list-style-type: none"> 1. Check connection between sensor board and control board. 2. If connection okay, call Technical Support.
2	Critical	Internal temperature sensor fault.	Temperature sensor non-existent, erratic or reads out of -20°F – 150°F range.	<ol style="list-style-type: none"> 1. Check connection between sensor board and control board. 2. If connection okay, call Technical Support.
3	Critical	Model 70 communication error.	Model 70 not communicating with dehumidifier control board.	<ol style="list-style-type: none"> 1. Check connections between Model 70 and control board. 2. If connections okay, turn off the dehumidifier and remove the Model 70. Use a short section of 4-wire cable to reconnect the Model 70 to the control board. Turn the dehumidifier back on and increase the dryness setting on the Model 70. If the dehumidifier turns on, the problem is with the wiring installed between the dehumidifier and the Model 70. 3. If the above does not fix the problem, call Technical Support.
4	Critical	Insufficient capacity.	After 120 minutes of compressor operation, the frost sensor temperature is not at least 10°F below the inlet air temperature.	<ol style="list-style-type: none"> 1. Check the frost sensor connection at the control board. 2. Remove the side panel (when facing side of unit, on/off switch will be on left) and verify the temperature sensor is not damaged, is fully inserted in the sensor well, and the well is filled with thermal paste. 3. If the sensor is not damaged and positioned correctly, contact Technical Support.
5	Non-Critical	Inlet air temperature out of range.	Internal temperature sensor reads out of 50°F – 105°F range for compressor operation. NOTE: If compressor is on when fault condition occurs, the compressor will turn off. If the compressor is not on when the fault condition occurs, there is no fault.	<ol style="list-style-type: none"> 1. Circulate air through the unit by setting the Cycle Period to 1 hour and Cycle Time to 60 minutes. After a minimum of 10 minutes, cycle power to the dehumidifier. 2. If fault persists, call Technical Support.
6	Critical	Frost sensor failure.	Frost temperature sensor nonexistent, erratic or reads out of -20°F – 150°F range.	<ol style="list-style-type: none"> 1. Check the frost sensor connection at the control board. 2. Remove the side panel (when facing side of unit, on/off switch will be on left) and verify the temperature sensor is not damaged, is fully inserted in the sensor well, and the well is filled with thermal paste. 3. If the fault persists, contact Technical Support.
7	Non-Critical	Float switch open.	Open circuit between float switch inputs.	<ol style="list-style-type: none"> 1. Empty the condensate pan. 2. Check the float switch connection at the control board. 3. If not using float switch, verify jumper is between float switch terminals on dehumidifier control board. 4. If the problem persists, replace the float switch.

TROUBLESHOOTING (CONTINUED)

TABLE 9 – Troubleshooting Guide

Symptom	Possible Reason	Troubleshooting Procedure													
Dehumidifier does not turn on/run.	No power to unit.	<ul style="list-style-type: none"> • Check that the dehumidifier is plugged in. • Check that the power switch on the dehumidifier is ON. • Check that control knob is set to a dryness level number. • Check that the circuit breaker has not tripped. The 1750A requires a minimum of 8 amps and the 1770A requires a minimum of 14 amps. 													
Dehumidifier blower is running but little or no airflow.	Pressure drop across dehumidifier is higher than 0.8" w.c. (1750A) or 1.5" w.c. (1770A).	<ul style="list-style-type: none"> • Check dehumidifier air filter and wash or replace. • Check for blocked duct work and clear. • Check if back flow damper is blocked or stuck and remove obstruction. 													
Dehumidifier blower is running but compressor is not.	Float switch open.	<ul style="list-style-type: none"> • If float switch installed, check connections at control board and empty condensate pan. • If no float switch installed, check that the jumper is installed at the float switch terminals on control board. 													
	Coil frosting.	<ul style="list-style-type: none"> • Lack of, or reduced airflow. Check/clean filter and check for blocked duct work. • Inlet air conditions below 60°F. Use the control knob to turn down the dryness setting. 													
The dehumidifier damper does not open in TEST Mode.	Incorrect damper wiring or bad connection.	<ul style="list-style-type: none"> • Verify wiring between dampers and 24 VAC transformer. • If wired for Convertible operation, verify that 24 VAC transformer is 40 VA minimum. • Check all wiring connections between dampers and control board. 													
HVAC fan does not turn on when CYCLE TIME potentiometer is turned to TEST.	No power to HVAC equipment.	<ul style="list-style-type: none"> • Verify there is power to the HVAC equipment. 													
	No power to dehumidifier.	<ul style="list-style-type: none"> • Check the voltage across the R & C terminals on the dehumidifier control board. Voltage should be 18 VAC – 30 VAC. 													
	Incorrect wiring.	<ul style="list-style-type: none"> • Verify wiring and connections between the thermostat, HVAC, and dehumidifier. 													
HVAC fan operates continuously after control knob is moved out of TEST.	HVAC call or constant fan.	<ul style="list-style-type: none"> • HVAC equipment is making a call. • The HVAC fan is set to constant ON. 													
	Dehumidifier air cycling/ventilation set to constant ON.	<ul style="list-style-type: none"> • If the Cycle Time is equal to or greater than the Cycle Period, HVAC fan operation will be continuous. • Reduce the Cycle Time if constant fan is not desired. 													
The ventilation damper does not open when the HVAC fan is active.	Cycle time met.	<ul style="list-style-type: none"> • The damper will not open if the Cycle Time has already been met. 													
	ODT error or inlet air out of temperature range.	<ul style="list-style-type: none"> • Check that the ODT is wired correctly to dehumidifier control board and connections are secure. • Check that ODT is installed in the outdoor air intake according to set-up in Ventilation Section starting on page 12. • Remove the ODT leads from the dehumidifier control board and check the resistance. Compare the reading with the table at right. <table border="1" style="float: right; margin-left: 20px;"> <thead> <tr> <th>Outdoor Temperature</th> <th>Resistance</th> </tr> </thead> <tbody> <tr> <td>0°F</td> <td>84,500 OHMS</td> </tr> <tr> <td>20°F</td> <td>46,000 OHMS</td> </tr> <tr> <td>40°F</td> <td>26,000 OHMS</td> </tr> <tr> <td>60°F</td> <td>15,500 OHMS</td> </tr> <tr> <td>80°F</td> <td>9,500 OHMS</td> </tr> <tr> <td>100°F</td> <td>6,000 OHMS</td> </tr> </tbody> </table>	Outdoor Temperature	Resistance	0°F	84,500 OHMS	20°F	46,000 OHMS	40°F	26,000 OHMS	60°F	15,500 OHMS	80°F	9,500 OHMS	100°F
Outdoor Temperature	Resistance														
0°F	84,500 OHMS														
20°F	46,000 OHMS														
40°F	26,000 OHMS														
60°F	15,500 OHMS														
80°F	9,500 OHMS														
100°F	6,000 OHMS														
Dehumidifier is not draining properly.	Drain line or drain trap blocked.	<ul style="list-style-type: none"> • Check that the drain trap is installed correctly. • Check the drain trap and drain line for blockage by slowly pouring one pint of water into the dehumidifier drip pan located below the coil. • Check drain line for continuous downward slope. 													
The HVAC fan turns on unexpectedly.	Sampling or air cycling.	<ul style="list-style-type: none"> • Dehumidifier will turn on HVAC fan during sampling and as needed to meet air cycling or ventilation requirements as determined by the Cycle Period and Cycle Time. 													
Dehumidifier is producing hot air.	Normal function.	<ul style="list-style-type: none"> • Air is reheated across the condenser coil, resulting in a temperature rise between inlet and outlet. 													

