

Owner's Manual — Phoenix AirMax

Installation, Operation & Service Instructions

Read and Save These Instructions

The Phoenix AirMax is the new leader in performance, convenience, portability, and safety for low profile air movers. Its compact 20 1/2" X 17" footprint and 8 7/8" height make the Phoenix AirMax the most compact and portable fan in its class. The rugged molded in handle gives you the solid control required when packing and unpacking lots of air movers. Its easy-winding cord wrap and multiple securement options makes it a snap to prep for transport. Because of its deeply-molded interlocking features, the Phoenix AirMax is rock solid when stacked for transport.

With its Patent Pending, low resistance motor support bracket and optimized outlet shape, the Phoenix AirMax delivers airflow of over 925 CFM. This gives you high velocity air over a 25% larger area than other low profile air movers. In addition, the Phoenix AirMax is stable on all 5 sides for maximum flexibility to position and direct the drying.

The Phoenix AirMax is the safest fan in its class providing a quality GFCI convenience receptacle that protects not only connected loads, but onboard components as well. This is unlike competing fans that require external GFCI protection. In addition, where competitors position high voltage electrical connections low to the floor, the leading edge design of the Phoenix AirMax allows these connections to be located more than 4 times the minimum required height. The Phoenix AirMax is built to keep our customers, and their customers, safe.



Phoenix now offers this unit in both Red and Blue

Phoenix AirMax
 PN 4035000 (Red)
 4035060 (Blue)



US Patent D782, 022
Other Patents Pending

©Technologies Holdings Corp.

The Phoenix AirMax

- 925 CFM, 1.9A
- Onboard circuit breaker and branch protection GFCI
- Daisy chain up to 6 fans on a single 15 Amp circuit
- Ultra secure stacking and cord wrap
- All Stainless Steel Fasteners

Specifications subject to change without notice.

TS-890
 05/17 Rev. C

Table of Contents

Introduction.....	1
1. Specifications	2
2. Important Safety Instructions	2
3. Operation	2
3.1 Transporting the Phoenix AirMax	2
3.2 Electrical Requirements.....	2
3.3 Ducting.....	2
3.4 Resettable Circuit Breaker	3
3.5 GFCI Protection and On-Board Duplex Receptacle .	3
4. Maintenance	3
4.1 Power Cord.....	3
4.2 Cleaning.....	3
4.3 Service	3
5. Wiring Diagram	4
6. Service Parts.....	5
Warranty.....	6

Serial No. _____

Purchase Date _____

Dealer's Name _____

Read the operation and maintenance instructions carefully before using this unit. Proper adherence to these instructions is essential to obtain maximum benefit from your Phoenix AirMax.

1 Specifications

Part No.	4035000 (Red) 4035060 (Blue)
Power	110-120 VAC, 1.9 Amps
Blower	925 CFM
Cord	20ft 6in Power Cord
Warranty	One Year, 100% Parts and Labor
Dimensions	Width 17" Height 8 7/8" Depth 20 1/2" Weight 21 lbs.

2 Important Safety Instructions

CAUTION

CAUTION: Risk of electric shock. Can cause injury or death to reduce the risk of electric shock:

- Do not expose to standing water or rain
- Unplug fan before servicing.
- Do not block air intake or outlet. One foot minimum distance to obstructions.

Indoor use only

- Do not use as stool or bench
- Do not operate with damaged cord or plug.
- Do not run cord under carpeting. Do not cover cord with throw rugs, runners, or similar coverings. Do not route cord under furniture or appliances. Arrange cord away from traffic area and where it will not be tripped over.

WARNING

WARNING: Not Suitable for use with Solid-State Speed Controls

AVERTISSEMENT: Ne Convient Pas a Des Regulateurs De Vitesse a Semi-Conducteurs

3 Operation

3.1 Transporting the Phoenix AirMax

The Phoenix AirMax is designed to be stacked vertically or horizontally ("Bookshelf Stacking") for transport.

3.2 Electrical Requirements

The Phoenix AirMax can be plugged directly into any standard wall receptacle. Without ducting, the Phoenix AirMax will draw 1.9 amps at 120 VAC. Ducting will reduce amp draw. Up to 6 Phoenix AirMaxs can be daisy chained on a standard 15 amp branch circuit.

3.3 Ducting

The lip on the exhaust opening of the Phoenix AirMax is designed to accommodate layflat ducting with 14" or larger diameter.

3.4 Resettable Circuit Breaker

The 12 Amp thermal circuit breaker protects the unit and devices connected to its duplex GFCI receptacle. In case of a fault, the breaker can be reset at the Phoenix AirMax control panel.

Use of multiple fans and any other connected devices must be in accordance with the National Electric Code and any additional codes or laws required by your local government.

! IMPORTANT

IMPORTANT: Total amperage of the Phoenix AirMax plus all devices plugged into its convenience receptacle is limited by the onboard circuit breaker. Excessive current will cause the circuit breaker to trip. This may occur instantly or after a period of time depending on the operating conditions.

! IMPORTANT

IMPORTANT: When the Phoenix AirMax is plugged into a standard "powered" wall outlet the Phoenix AirMax's duplex outlet is electrically "HOT" and AC voltage is present.

3.5 GFCI Protection and the On-Board Duplex Receptacle

The on-board convenience receptacle provides electrical shock protection for the operator in damp or wet applications or other conditions that would cause a ground fault. The Phoenix AirMax is wired to branch protect all on-board components in addition to protecting any fans or other equipment plugged into the onboard receptacle.

Testing GFCI operation can be done by pressing the "TEST" button located on the GFCI duplex outlet. If operating properly, the "RESET" button will pop out. In addition, notice that the fan will NOT operate if the GFCI outlet is in the TRIPPED condition as the motor and other on-board components are included in the GFCI protected circuit.

The GFCI circuit can only be "RESET" when the Phoenix AirMax is connected to a properly grounded wall outlet providing the rated voltage.

4 Maintenance

! WARNING

WARNING: Disconnect the unit from power before servicing or cleaning. Replace all safety grills after servicing or cleaning

4.1 Power Cord

Visually inspect cord and plug head before use. If there are signs of damage or excessive wear, discontinue use until the unit has been serviced.

4.2 Cleaning

The housing is made of durable and washable polypropylene. When cleaning, the use of solvents is NOT recommended.

When washing inside the unit, disconnect the unit from its power source. Protect the switch, receptacle and circuit breaker from water intrusion. Do not spray water or cleaning solution at motor. If motor does get wet, allow motor to dry completely before restarting. If fan is to be washed and not used within 24 hours, allow fan to drip dry for 10 minutes and then run for 5 minutes before storing.

! IMPORTANT

IMPORTANT: Do NOT remove impeller blade from motor assembly. Doing so can cause blade to become imbalanced upon re-assembly.

4.3 Service

! CAUTION

CAUTION: Servicing the Phoenix AirMax with its high voltage circuitry presents a health hazard that could result in death, serious bodily injury, and/or property damage. Disconnect the appliance from the power supply before servicing. Only qualified service people should service this unit.

! CAUTION

CAUTION: If the supply cord or GFCI become damaged, they must be replaced by the manufacturer, its service agent or similarly qualified person in order to avoid a hazard.

5 Wiring Diagram

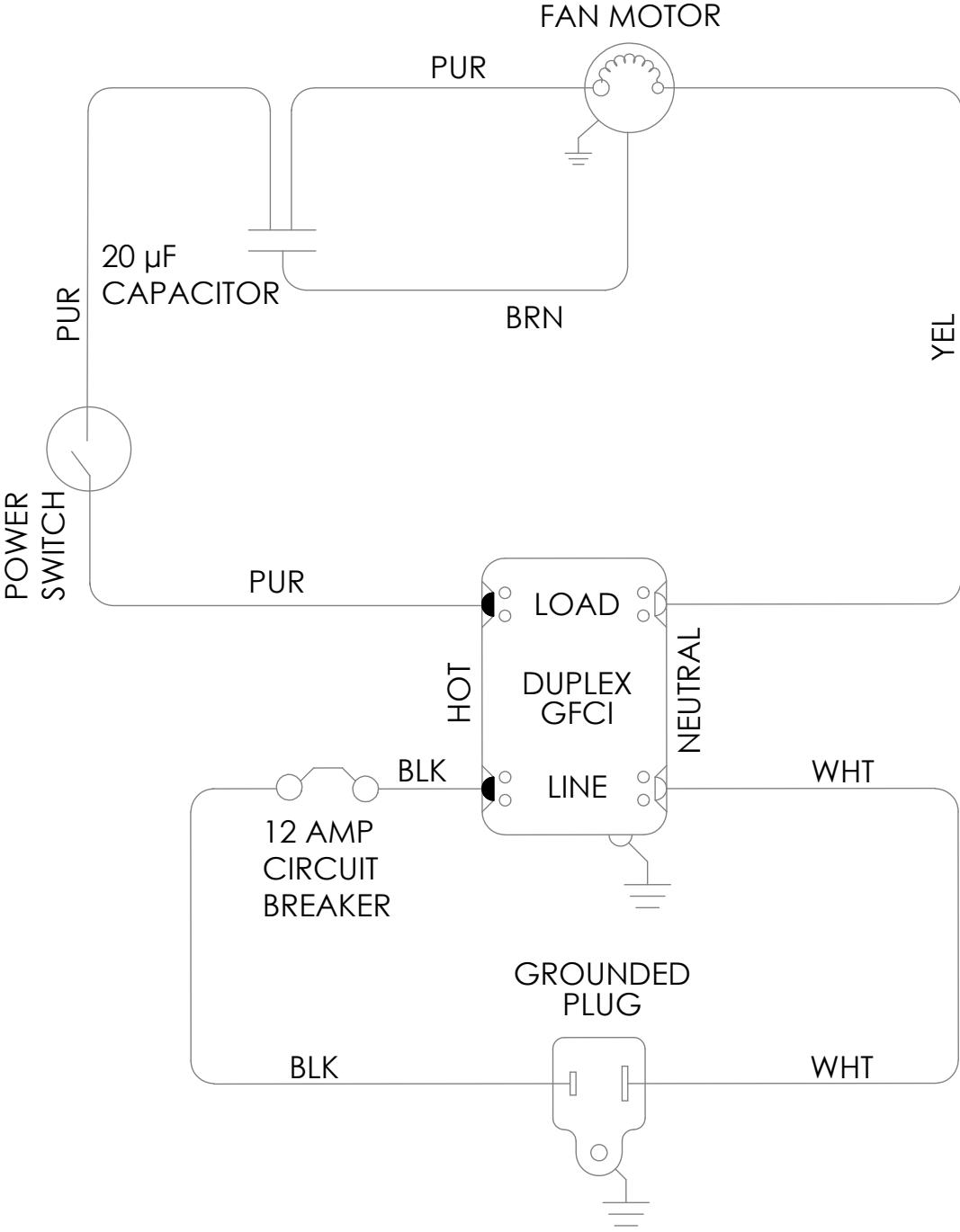

6 Service Parts

Part No.	Description	Optional Parts
4035662	Impeller Assembly	4024936 Duct, Lay Flat, 14" x 250'
4036557	Power Cord Kit (20' cord, bolts & nuts)	
4035235-08	Run Capacitor, 20 mfd, 370 VAC	
4035665	Rubber Feet	
4036256	Duplex GFCI Outlet Kit	
4035825	Rocker Switch	
4035752	12A Circuit Breaker	
4037469	Inlet Grill	
4036486	20' Cord Only	

This page intentionally left blank.

Phoenix AirMax Limited Warranty

Warrantor:

Therma-Stor LLC
4201 Lien Rd
Madison, WI 53704
Telephone: 1-800-533-7533

Who Is Covered: This warranty extends only to the original end-user of the AirMax Fan, and may not be assigned or transferred.

First Year Warranty: Therma-Stor Products warrants that, for one (1) year the AirMax Fan will operate free from any defects in materials and workmanship, or Therma-Stor Products will, at its option, repair or replace the defective part(s), free of any charge.

End-User Responsibilities: Warranty service must be performed by a Servicer authorized by Therma-Stor Products. If the end-user is unable to locate or obtain warranty service from an authorized Servicer, he should call Therma-Stor Products at the above number and ask for the Therma-Stor Products Service Department, which will then arrange for covered warranty service. Warranty service will be performed during normal working hours.

The end-user must present proof of purchase (lease) upon request, by use of the warranty card or other reasonable and reliable means. The end-user is responsible for normal care. This warranty does not cover any defect, malfunction, etc. resulting from misuse, abuse, lack of normal care, corrosion, freezing, tampering, modification, unauthorized or improper repair or installation, accident, acts of nature or any other cause beyond Therma-Stor Products' reasonable control.

Limitations and Exclusions: If any AirMax Fan part is repaired or replaced, the new part shall be warranted for only the remainder of the original warranty period applicable thereto (but all warranty periods will be extended by the period of time, if any, that the AirMax Fan is out of service while awaiting covered warranty service).

UPON THE EXPIRATION OF THE WRITTEN WARRANTY APPLICABLE TO THE AirMax Fan OR ANY PART THEREOF, ALL OTHER WARRANTIES IMPLIED BY LAW, INCLUDING MERCHANTABILITY AND FITNESS FOR A PARTICULAR PURPOSE, SHALL ALSO EXPIRE. ALL WARRANTIES MADE BY THERMA-STOR PRODUCTS ARE SET FORTH HEREIN, AND NO CLAIM MAY BE MADE AGAINST THERMA-STOR PRODUCTS BASED ON ANY ORAL WARRANTY. IN NO EVENT SHALL THERMA-STOR PRODUCTS, IN CONNECTION WITH THE SALE, INSTALLATION, USE, REPAIR OR REPLACEMENT OF ANY AirMax Fan OR PART THEREOF BE LIABLE UNDER ANY LEGAL THEORY FOR ANY SPECIAL, INDIRECT OR CONSEQUENTIAL DAMAGES INCLUDING WITHOUT LIMITATION WATER DAMAGE (THE END-USER SHOULD TAKE PRECAUTIONS AGAINST SAME), LOST PROFITS, DELAY, OR LOSS OF USE OR DAMAGE TO ANY REAL OR PERSONAL PROPERTY.

Some states do not allow limitations on how long an implied warranty lasts, and some do not allow the exclusion or limitation of incidental or consequential damages, so one or both of these limitations may not apply to you.

Legal Rights: This warranty gives you specific legal rights, and you may also have other rights which vary from state to state.

